

WARNING: Do Not Operate Before Reading Manual

PD Plus OPERATOR'S MANUAL

Models

9016
9020
9027

Horizontal Air Flow

Vertical Air Flow

Horizontal Flow, Single Envelope

Gastight Vertical Flow, Single

Envelope Gastight Horizontal Flow,

Double Envelope Gastight Vertical

Flow, Double Envelope Gastight

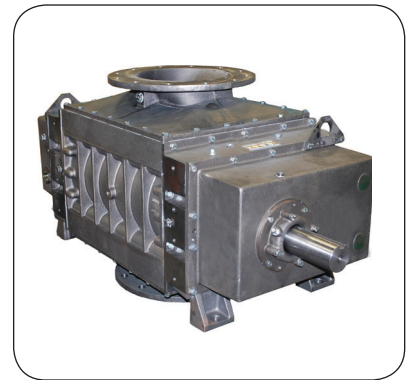

The employees of Tuthill Vacuum & Blower Systems thank you for your purchase!

Tuthill Vacuum & Blower Systems proudly manufactures Kinney® vacuum pumps and M-D Pneumatics™ blowers and vacuum boosters in Springfield, Missouri, USA. We bring 100+ years of engineering experience and solid, hands-on care to help customers keep their processes running. Your satisfaction is important to us so please take time to provide your Tuthill sales representative with performance feedback. We love to hear from our customers!

Tuthill is a family owned business that was started by James B. Tuthill in 1892. At that time, Tuthill manufactured common brick to Chicago construction companies who were fueling the city's rapid expansion. Fast forward to today and Tuthill now serves sustaining, global markets like agriculture, chemical, construction, energy, food and beverage, pharmaceuticals and medical, transportation, and utilities. While the company has changed in what it manufactures, one thing remains throughout every Tuthill line of business – we are a company with HEART. Our slogan is “Pump Your Heart Into It” and everyday our employees do just that as they represent the Tuthill brand and dare to make better.

Thank you for making Tuthill Vacuum & Blower Systems part of your company's process!

A company with heart right from the start.



FIND OUT MORE AT
TUTHILL.COM

Disclaimer Statement:

All information, illustrations and specifications in this manual are based on the latest information available at the time of publishing. The illustrations used in this manual are intended as representative reference views only. Products are under a continuous improvement policy. Thus, information, illustrations and/or specifications to explain and or exemplify a product, service or maintenance improvement may be changed at any time without notice.

Rights Reserved Statement:

No part of this publication may be reproduced or used in any form by any means - graphic, electronic or mechanical, including photocopying, recording, taping or information storage and retrieval systems - without the written permission of Tuthill Vacuum & Blower Systems.

Copyright © 2017 Tuthill Vacuum & Blower Systems
All rights reserved. Product information and specifications subject to change.

Table of Contents

Introduction	1
Applicable Documentation	1
Scope of Manual.....	1
Conventions and Data Plate	2
Graphic Conventions in this Manual	2
Data Plate.....	3
Lifting	5
Description	6
Flow by Direction.....	7
Specifications.....	8
General	10
Location.....	12
Foundation.....	12
Blower Air Intake	12
Soft Foot	13
Safety	13
Lubrication	14
Filling Procedure	15
Recommended Oil Change Intervals.....	16

Frequently Asked Questions Regarding Lubrication	17
Hazards Associated With Breakdown or Ignition of Lubrication	17
Lubrication – Integral Pressure (19, 86, 55, 82, 66, 69 Series).....	17
Oil Filter	17
Oil Pressure Adjustment.....	18
Oil Cooler	18
Piping Connections.....	18
Hazards Associated With Hazardous Process Fluids.....	19
Blockage or Restriction	19
Motor Drives	19
Direct Coupled.....	19
V-Belts	19
Setting V-Belt Tension.....	20
Motor and Electrical Connections	22
Operation	23
General	23
Start-Up Checklist.....	24
Operating	25
Water-Injected Blowers.....	25
Operation	26
Shutdown	26
Recommended Shutdown Procedure to Minimize Risk of Freezing or Corrosion	26
Maintenance	28
General	28
Regular Maintenance.....	28

Spare Parts	29
Factory Service and Repair	29
Long-Term Storage	30
Disassembly and Reassembly.....	31
Disassembly of Blower	31
Free End Disassembly	31
Gear End Disassembly (Series 17/19/46/55/57/81/82/86)	31
Gear End Disassembly (Series 64/66/67/69)	31
End Plate and Rotor Disassembly.....	32
Assembly Of Blower	32
Preparation of End Plates for Assembly	32
Lip Seal Installation (Series 17/19/46/86).....	32
Lip Seal Installation (Series 55/57/64/66/67/69/81/82).....	33
Gear End Assembly	33
End Plate Installation (Series 55/57/64/66/67/69/81/82)	33
Free End Assembly	34
Free End Assembly (Series 55/57/64/66/67/69/81/82).....	34
Adjusting Interlobe Clearance	35
Complete Drive End Assembly	35
Complete Drive End Assembly (Series 17/19/46/55/57/81/82/86)	35
Complete Drive End Assembly (Series 17/19/46/55/57/81/82/86)	35
Complete Free End Assembly (Series 17/46/57/64/67/81)	35
Complete Free End Assembly (Series 19/55/66/69/82/86)	36
Special Instructions for Gear Head Blowers.....	36
Troubleshooting.....	37

Assembly Clearances..... 39

Torque Chart..... 40

Recommended Lubricants..... 41

 Recommended Lubricants for Rotary Blowers and Vacuum
 Boosters 41

Special Tool Drawings..... 43

 Parts List 44

 Assembly Drawings 50

INTRODUCTION

CONGRATULATIONS on the purchase of a new **PD PLUS Rotary Positive Displacement Blower** from Tuthill Vacuum & Blower Systems. Please examine the blower for shipping damage, and if any damage is found, report it immediately to the carrier. If the blower is to be installed at a later date, make sure it is stored in a clean, dry location and rotated regularly. Make sure covers are kept on all openings. If the blower is stored outdoors, be sure to protect it from weather and corrosion.

PD PLUS blowers are built to exacting standards and, if properly installed and maintained, will provide many years of reliable service. Read and follow every step of these instructions when installing and maintaining the blower.

NOTE: Record the blower model and serial numbers of the machine in the **OPERATING DATA** form on the inside back cover of this manual. Use this identification on any replacement part orders, or if service or application assistance is required.

APPLICABLE DOCUMENTATION

The applicable documents associated with this manual are:

- 2006/42/CE – Machinery Directive
- EN 1012-1:1996 - Compressors and vacuum pumps - Safety Requirements - Part 1: Compressors

SCOPE OF MANUAL

The scope of this manual and the Declaration of Incorporation includes the bare shaft rotary positive displacement blower.

02

CONVENTIONS AND DATA PLATE

GRAPHIC CONVENTIONS IN THIS MANUAL

This manual is the result of a risk assessment according to the applicable documents referenced in **Applicable Documentation on page 1**. The following are hazard levels are referenced within this manual:

DANGER

Indicates a hazardous situation that, if not avoided, will result in death or serious injury.

WARNING

Indicates a hazardous situation that, if not avoided, could result in death or serious injury.

CAUTION

Indicates a hazardous situation that, if not avoided, could result in minor or moderate injury.

NOTICE

Indicates a situation that can cause damage to the engine, personal property, and/or the environment or cause the equipment to operate improperly.

NOTE: Indicates a procedure, practice, or condition that should be followed in order for the equipment to function in the manner intended.

CAUTION







Read manual before operation or bodily harm may result. Attention should be given to the safety related sections of this manual.

DATA PLATE

MODEL NUMBER	SERIAL NUMBER	MAWP	YEAR
		Tuthill Vacuum & Blower Systems 4840 West Kearney Street Springfield, Missouri USA 65803	
		MAX RPM _____	

READ INSTRUCTION MANUAL BEFORE OPERATION OR BODILY HARM MAY RESULT

 WARNING Keep body & clothing away from machine openings.	 WARNING Do not operate without guards in place.	 CAUTION Hearing protection required.	 CAUTION Do not touch hot surfaces.
---	--	--	---

<http://www.tuthill.com>
(800) 825-6937
Made in the USA

Figure 2-1 – General Operation and Symbols on Data Plate

The following information is contained on the data plate:

 WARNING	Keep body & clothing away from machine. During operation, keep body and clothing away from inlet and outlet of the blower.
 WARNING	Do not operate without guards in place.

 CAUTION	Hearing protection is required while the blower is in operation. Noise levels may reach as high as 81 dBA.
 CAUTION	Do not touch hot surfaces. The upper limit of the blower operation is 400°F (205°C). Do not touch the blower while it is in operation and assure blower is cool when not in operation.

MODEL NUMBER: The specific model of the blower

SERIAL NUMBER: Unique to each blower

YEAR: Year of manufacture

MAWP: Maximum Allowable Working Pressure

The standard MAWP is per **Table 4-2 – Maximum Operating Limits on page 8**. The MAWP shall not be exceeded.



WARNING

The blower must be handled using an appropriate device such as a fork truck or appropriate lifting device. See *Table 4-1 on page 8* for approximate weights. Care should be taken to assure blower does not over-turn during handling and installation.

04

DESCRIPTION

NOTICE

Refer to specific data sheets for flow capacities and vacuum capacities.

NOTE: Refer to diagrams in this manual for proper rotation and orientation in inlet and discharge.

Tuthill Vacuum & Blower Systems model 9000 Series rotary lobe blowers are positive displacement type blowers, whose pumping capacity is determined by size, operating speed, and differential pressure conditions. Blowers employ rotors rotating in opposite directions within a housing closed at the ends by end plates.

The inlet to the discharge is sealed with operating clearances that are very small. Internal lubrication is not needed, as there is no moving contact.

Clearances between the rotors during rotation are maintained by a pair of accurately machined helical timing gears, mounted on the two shafts extended outside the air chamber. The intermeshing rotary lobes are designed to rotate and trap air or gas between each rotor and the housing. As the rotor lobes rotate past the edge of the suction port, the trapped air or gas is essentially at suction pressure and temperature. Since the blower is a constant volume device, the trapped air remains at suction pressure until the leading rotor lobe opens into the discharge port. The close clearances between the rotors inhibit back slippage of the trapped volume from between the rotors, and the trapped volume is forced into the discharge piping. Compression occurs not internal to the blower but by the amount of restriction, either downstream of the blower discharge port or upstream of the blower inlet port.

Figure 4-1 illustrates the air movement within the machine. In addition, the machine can operate in either direction. **See Flow by Direction on page 7.**

Never attempt to control capacity by means of a throttle valve in the intake or discharge piping. This will increase the power load on the drive system, will increase operating temperatures, and can overload and/or seriously damage the blower. Likewise, if the possibility exists that flow to the blower inlet may be cut off during normal operation of a process, install an adequate vacuum relief valve. A pressure-type relief valve in the discharge line near the blower is also recommended for protection against cutoff or blocking in this line. Use check valves on each blower when more than one blower is connected to a discharge line.

When a belt drive is used, it is possible to adjust blower speed to obtain the desired capacity by changing the diameter of one or both sheaves, or by using a variable-speed motor pulley. In a direct-coupled arrangement, a variable-speed motor or transmission is required. Gas blowers can use bypasses, but some applications may require additional cooling. If there is a large volume of high-pressure air or gas downstream of the blower, a check valve in the piping downstream of the blower will protect the blower from overspeeding in a backward direction upon shutdown.

Consult a Tuthill Vacuum & Blower Systems sales professional if questions arise.

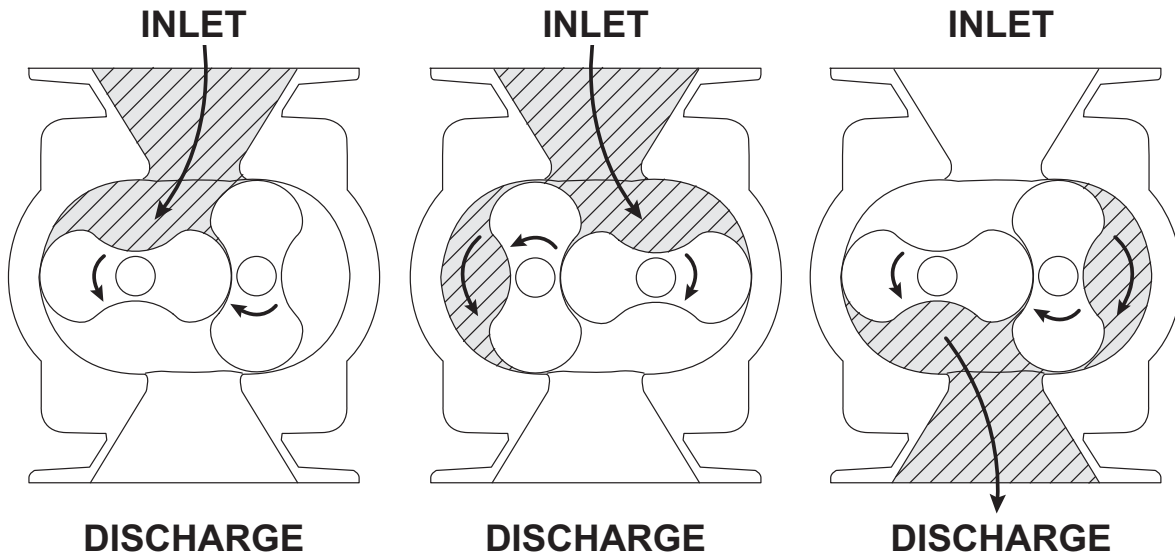

Figure 4-1 – General Operation Principle

FLOW BY DIRECTION

! WARNING

Refer to diagrams in this manual for proper rotation and orientation in inlet and discharge.

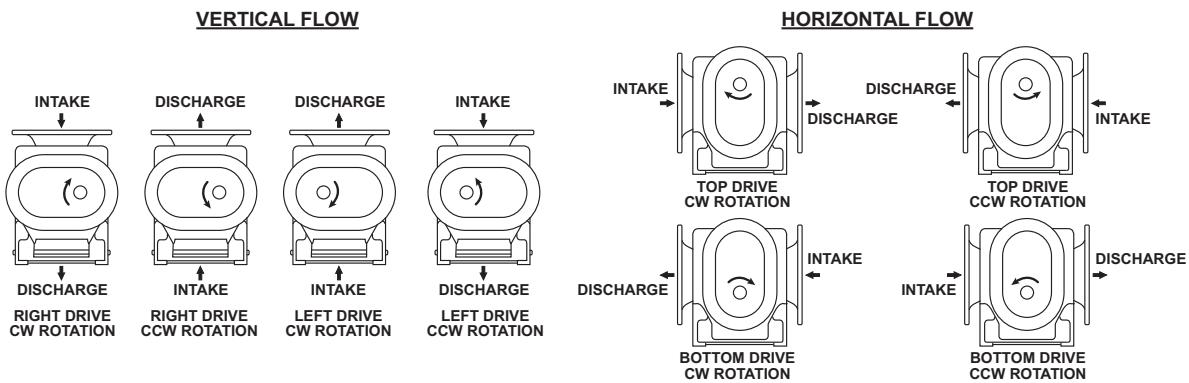

Figure 4-2 – Flow Direction by Rotation

SPECIFICATIONS

MODEL	APPROXIMATE OIL CAPACITY		PORT SIZE	MAX RPM	APPROXIMATE WEIGHT	
	VERTICAL FLOW	HORIZONTAL FLOW			VERTICAL FLOW	HORIZONTAL FLOW
9016	8.0 gal (30.3 L)	5.0 gal (18.9 L)	12 in. (305 mm)	2400	2000 lb (907 kg)	2000 lb (907 kg)
9020	8.0 gal (30.3 L)	5.0 gal (18.9 L)	12 in. (305 mm)	2400	2300 lb (1043 kg)	2300 lb (1043 kg)
9027	8.0 gal (30.3 L)	5.0 gal (18.9 L)	14 in. (356 mm)	2400	2850 lb (1292 kg)	2850 lb (1292 kg)

Table 4-1 – Specifications

MODEL	MAXIMUM RPM	MAXIMUM PRESSURE DIFFERENTIAL	MAXIMUM VACUUM	MAXIMUM TEMPERATURE RISE	MAWP
9016	2400	15 psi (1,035 mbar)	15 inch-Hg (508 mbar)	280°F (156°C)	35 psi (2.4 bar)
9020					
9027					

Table 4-2 – Maximum Operating Limits

WARNING

The maximum pressure differential is based on the difference between the inlet pressure and the outlet pressure. The maximum pressure differential shall not be exceeded. Exceeding the maximum pressure differential will cause serious damage to the equipment and could cause bodily injury.

To permit continued satisfactory performance, a blower must be operated within certain approved limiting conditions. The manufacturer's warranty is, of course, also contingent on such operation. Maximum limits for pressure, temperature, and speed are specified in **Table 4-2** for various blower sizes when operated under the standard atmospheric conditions. Do not exceed any of these limits.

WARNING

The maximum allowable working pressure (MAWP) is based on the absolute pressure of the blower housing and is NOT the maximum allowable pressure differential. Exceeding the MAWP will cause serious damage to the equipment and could cause bodily injury.

*Specially ordered blowers with nonstandard construction, or with rotor end clearances greater than shown in **Assembly Clearances on page 39**, will not have the operating limits specified here. Contact your Tuthill Vacuum & Blower Systems sales representative for specific information.*

NOTICE

Special attention must be paid when a blower has a higher than standard ambient suction temperature. Special recommendations for operating parameters and/or additional cooling may be recommended. Consult the factory or local representative for appropriate information.

05

INSTALLATION

GENERAL

DANGER

The booster is not intended to be used with explosive products or in explosive environments unless fully approved by Tuthill Factory prior to the purchase of the product, designed specifically for the gas application.

DANGER

It is the responsibility of the installer to assure that proper guarding is in place and compliant with all applicable regulatory requirements.

WARNING



The bare shaft blower can generate excessive noise. Methods to reduce the noise levels by installing inlet and outlet silencers will be required. Even with inlet and outlet silencers, hearing protection will be required.

WARNING

Customers are warned to provide adequate protection, warning and safety equipment necessary to protect personnel against hazards in the installation and operation of this equipment in the system or facility.

WARNING

The standard MAWP is per *Table 4-2*. The MAWP shall not be exceeded unless specific factory testing of the pressure containing components of the blower has been performed.

WARNING

Table 4-2 states the maximum operating speed in RPM (rotations per minute) and maximum temperature. Do not exceed these limits. The installation of the blower shall take these critical operating parameters into account and adequate control features implemented.

WARNING

Upon completion of the installation, and before applying power, rotate the drive shaft by hand. It must move freely. If it does not, look for uneven mounting, piping strain, excessive belt tension or coupling misalignment or any other cause of binding. If blower is removed and still does not move freely, check inside the blower housing for foreign material.

NOTICE

Remove the protective covers from the shaft and inspect for damage.

Carefully check to ensure that no transit damage has been sustained. If damage has occurred from shipment, file a claim with the carrier immediately. Preserve the shipping container for inspection by the carrier.

NOTICE

In the event that your unit sustains damage while being shipped to your facility, do not return it to the factory without first obtaining shipping instructions from us.

Do not remove protective covers and plugs until the connections are complete. Mount the blower on a flat, level surface. Use a baseplate that is rigid, solidly supported, and structurally sound. Shim under the legs where necessary so that each leg of the blower supports an equal share of the blower weight. This is necessary to prevent twisting of the blower. Make sure the feet rest evenly on the mounting surface before fastening down. Twisting or cramping the blower during mounting will cause rotor contact and binding during operation, resulting in a condition called "soft foot." **See Soft Foot on page 13** for further details and preventative measures.

A blower that is factory-mounted on a base should not require such adjustments. However, since the assembly can become twisted in shipping or installation, check for soft foot after installing the

base. Shims may be needed for alignment. Loosen the foot hold-down screws to check foot contact with the mounting surface. Mount the base on a solid foundation or heavy flooring, using shims as necessary at bolting points to prevent warping the assembly. **See Foundation on page 12** for more information.

Transmission of small operating vibrations to a support structure may be objectionable in some applications. Use of vibration isolators or vibration-absorbing materials can be effective in overcoming this transmission. To avoid causing distortion, apply the treatment under the common motor/blower base or mounting plate rather than directly under the feet alone.

Make sure piping is accurately squared with the blower and supported independently. Stress imparted from incorrectly aligned piping or mounting will create problems with bearing and seal life, possibly leading to premature internal contact. The blower should sit stress free and evenly on its supporting surface. Take care to evenly tighten the mounting bolts to avoid imparting undue stress into the blower. Stress can be checked in a free state with feeler stock or verified on a previously installed blower with the aid of a dial indicator. Spring or gap should be less than 0.002 in. (0.05 mm).

Use only clean, new pipe and make certain it is free of scale, cuttings, weld beads, dirt, or any other foreign material. To guard against damage to the blower, make sure that an inlet filter is used. Clean the filter of collected debris after 3 hours of operation and periodically thereafter. **See Piping Connections on page 18** for additional details.

Figure 5-1 shows a typical complete installation of the blower and accessories. Note the absence of throttle or shut-off valves in both discharge and intake piping. If it is possible for airflow to be cut off in either line, add a pressure and/or vacuum relief valve. In some installations, it may be desirable to use only an inlet silencer-cleaner supported directly from the blower connection. Keep the weight of accessories and piping to a minimum to prevent blower casing distortion. If the weight exceeds 10% of blower weight, support the components independently of the blower and connect them with a flexible hose or connectors. The approximate weight of the blower is listed in **Table 4-1 on page 8**.

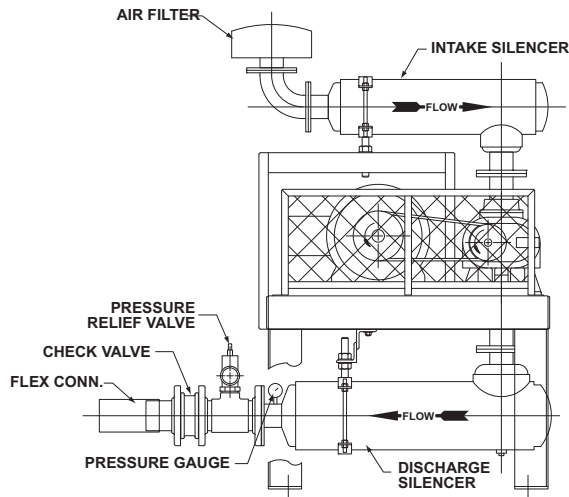

Figure 5-1 – Typical Blower Installation

A blower may be driven by direct-coupling to the driver or by V-belt drive for the purpose of obtaining other speeds within the approved range. **See Motor Drives on page 19** for more information.

Blowers from Tuthill Vacuum & Blower Systems are internally and externally treated after factory assembly and testing to protect against rusting in normal atmospheric conditions prior to installation. The maximum period of internal protection is considered to be 6 months under average conditions, provided closing plugs and seals are not removed. Protection against chemical or salt-water atmosphere is not provided. Avoid opening the blower until ready to begin installation, as protection will be quickly lost due to evaporation. For recommended preparations for long-term storage (longer than 6 months), **see Long-Term Storage on page 30**.

Location

Install the blower in a room or outdoor area that supplies adequate space and lighting for routine maintenance. Make sure that indoor installation areas are well ventilated and kept as cool as possible, because operating the blower at elevated temperatures can result in nuisance overload or temperature shutdowns. An unprotected outdoor installation is satisfactory only when correct lubrication for the expected temperatures is provided. **See Recommended Lubricants on page 41**.

Foundation

Your blower does not need a special foundation; however, it does require a solid, level floor and adequate frame support. Bolt the blower system to the floor and seal any cracks.

Blower Air Intake

To minimize maintenance, supply the blower with the cleanest air possible. The air must not contain any flammable or toxic gases, as the blower will concentrate these gases. This could result in damage to the blower and surrounding property and lead to personal injury or death. Do not block or restrict the opening of the blower, as the motor could overheat and fail.

Do not use blowers on explosive or hazardous gases. Do not exceed the limits described in **Table 4-2 on page 8** on performance criteria such as pressure differential, running speed, and discharge temperature.

If it is necessary to take air from a remote source, such as in a vacuum application, make sure the diameter of the piping is at least equal to the diameter of the blower inlet. For distances greater than 20 ft (6 m), enlarge the pipe diameter to reduce inlet restriction. Excessive restriction will reduce the efficiency of the blower and elevate its discharge temperature. The piping used should also be corrosion-resistant and free of scale and dirt. Keep the inlet covered to keep out foreign objects and rain. Vacuum kits are available.

Soft Foot

Soft foot is a condition in which one of the blower feet does not sit flat on the base. Soft foot is usually due to irregularities in the surface to which the blower is mounted. When the bolt on the foot gets tightened, a slight distortion occurs that can affect bearing and seal life as well as internal contact between parts.

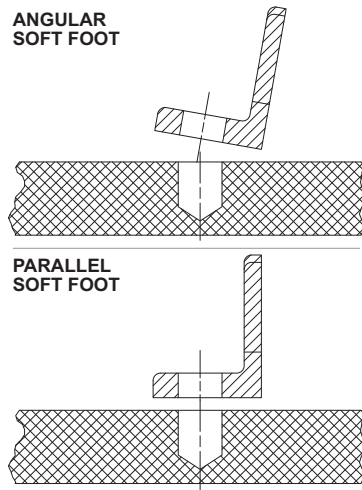

Figure 5-2 – Illustrations of Soft Foot

1. Place the blower on the base.
2. Check each foot for gaps between the foot and base (soft foot). Shim as necessary to fill the gap within 0.002 in. (0.05 mm). **Figure 5-2** shows the two most common types of soft foot conditions. If either type is present at a measurement of more than 0.003 in. (0.076 mm), the blower may fail prematurely.
3. Tighten all bolts.
4. Mount a dial indicator on the base contacting one foot at 12 o'clock position.
5. Loosen the bolt on that foot. Observe indicator travel and add shims as needed to reduce "spring" to less than 0.002 in. (0.05 mm). Repeat steps 4 and 5 on the remaining feet.

SAFETY

Tuthill Vacuum & Blower Systems recommends the use of relief valves to protect against excessive pressure or vacuum conditions. Test these valves at initial start-up to be sure they are properly adjusted to relieve at or below the maximum pressure differential rating of the blower.

DANGER



It is the responsibility of the installer to assure that proper guarding is in place and compliant with all applicable regulatory requirements.



DANGER



Internal and external rotating parts of the blower and driving equipment can produce serious physical injuries. The blower should never be run with the inlet or discharge piping removed. If it becomes necessary to inspect the rotating parts of the blower or to change V-belts, be absolutely sure that all power to the motor controls has been shut off, the motor controls are locked out, and properly tagged before proceeding.



 **DANGER**

Assure that properly sized vacuum breaks/relief valves are used on the inlet side of the blower. Also assure that properly sized pressure relief valves are used on the outlet of the blower. The sizing shall be such to assure that the proper flow can be achieved without exceeding the rated vacuum and pressure ratings.

 **DANGER**

Blower housing and associated piping or accessories may become hot enough to cause major skin burns on contact.

 **WARNING**

Use lock out/tag out procedures to disable the electrical energy source before any service or work is done on the blower.

 **WARNING**

Avoid extended exposure in close proximity to machinery with high intensity noise levels. Wear adequate ear protection.

NOTE: Use proper care and good procedures in handling, lifting, installing, operating, and maintaining the equipment.

LUBRICATION

Every blower from Tuthill Vacuum & Blower Systems is factory-tested, oil-drained, and shipped dry to its installation point. Fill both oil reservoirs to the proper level before operation.

Shaft bearings at the gear end of the blower are splash-lubricated by one or both gears dipping into an oil reservoir formed in the gear end plate and cover. Shaft bearings at the back end of the blower are lubricated by a slinger assembly dipping into an oil reservoir. In addition to the splash lubrication, blower series incorporate pressure lubrication with an integral oil pump, pressure relief valve, filter and oil-to-coolant heat exchanger. Before starting the blower, fill the oil sumps as described in *Filling Procedure on page 15*.

Tuthill Vacuum & Blower Systems approved mineral-based, synthetic and food grade lubricants are listed in *Recommended Lubricants on page 41*.

 **WARNING**

Never attempt to change or add lubrication while the blower is running. Failure to heed this warning could result in damage to the equipment or personal injury. Oil must be checked when the blower is NOT running.

 **WARNING**

Properly dispose of the spent lubricants. Refer to the manufacturer of the lubricant and any regulations to assure proper and safe disposal.

 **WARNING**

Do not start the blower until you are sure oil has been put in the gear housing and rear cover. Operation of the blower without proper lubrication will cause the blower to fail and void the warranty.

Filling Procedure

See **Recommended Lubricants on page 41** for suggested lubricants and grease.

1. Remove the large hex head fill plug from the back (non-drive) end cover.

2. Slowly pour oil through the fill until oil appears in the oil sight glass. Bring the oil level to the center of the sight glass.
3. Verify oil level is at proper level in both gear end and drive end sight glasses.
4. Replace and secure the fill plug that was removed in step 1.

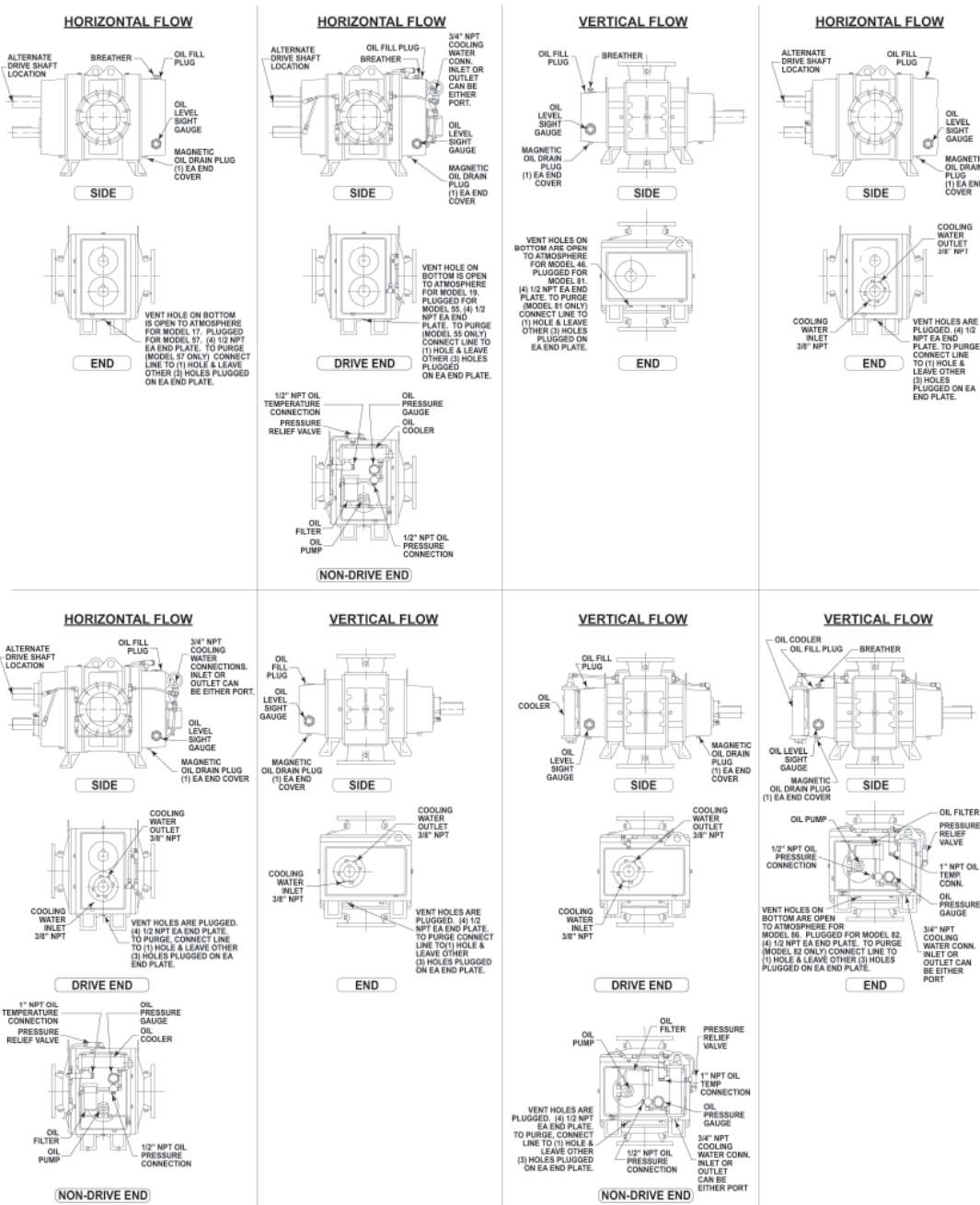

Figure 5-3 – Oil Fill, Drain, Level Gauges and Cooling Connections on Blowers with Splash Lubrication

Recommended Oil Change Intervals

Table 5-1 should only be used as an approximate guide. For best results, an oil sampling program is recommended.

The initial oil change should occur after the first 200 hours of operation. Thereafter, frequency of oil changes will depend on the operating conditions. Check for oil contamination periodically. Time between oil changes should never exceed six (6) months.

In addition, *see Recommended Lubricants on page 41.*

PRESSURE RANGE (PSIG) OR VACUUM RANGE (INCHES HG)	PRESSURE	VACUUM	OPERATING TIME BETWEEN OIL CHANGES
1-5	70-345 mbar	34-170 mbar	1500 hr
6-10	410-690 mbar	203-339 mbar	1000 hr
11-15	760-1035 mbar	370-508 mbar	500 hr

Table 5-1 – Operating Conditions (Pressure/Vacuum)

Frequently Asked Questions Regarding Lubrication

What is the functional detriment if the “wrong oil” is used?

The lubricant is selected based on bearing speed, gear speed, and operating temperature. If the lubricant is too light, it increases wear by not separating the sliding surfaces and it will not remove the heat adequately. If the lubricant is too thick, the drag in the bearings is increased, causing them to run hotter. Thicker lubricant will not flow as readily into the gears and it will reduce the available backlash. Lubricants at our conditions are incompressible.

What is the functional detriment if the oil is not serviced?

If the lubricant is not serviced at the proper interval, the shearing action in the bearing and the gears will begin to take its toll and the lubricant will thicken. The blower will run hotter and the wear on moving parts will increase. The lubricant will generally appear dirtier, caused by material rubbing off the components. The lubricant will discolor because of overheating. An indicator of the breakdown of a lubricant is the increase in the Total Acid Number (TAN) and a change of 10 percent in the base viscosity.

Several things are happening as the lubricant goes through the blower. First, it is absorbing frictional energy in the form of heat. This heat has to be dissipated through either surface contact with cooler materials or in a rest volume of lubricant. While reducing the friction, the lubricant is also going through a shearing process and the molecular structure is broken down.

The result is that the lubricant will begin to thicken because of the shorter molecular chains and the drop out of additive packages. The thickened lubricant will cause more drag, increasing the friction and heat and further degrading the lubricant.

Operation of the blower (environment, run time, speed, and pressure) has a direct effect on duty cycles. The published cycles are based on worst-case conditions.

Hazards Associated With Breakdown or Ignition of Lubrication

DANGER



There is a risk associated with the lubrication media breaking down and resulting in a hazardous fluid or vapor. There may also be a hazard associated with the ignition of the lubrication media. Refer to the lubrication manufacturer’s applicable instruction for safety precautions.

LUBRICATION – INTEGRAL PRESSURE (19, 86, 55, 82, 66, 69 SERIES)

Oil Filter

The oil filter is a self-contained, spin-on type. Change the oil filter element with every oil change. Filters are available from Tuthill Vacuum & Blower Systems, or from any authorized distributor or service center.

CAUTION

Factory-supplied filters are engineered to provide the proper restriction in the oil lubrication system. Using filters other than those available from Tuthill Vacuum & Blower Systems may result in lubrication problems and possibly unwarrantable damage to the blower.

Oil Pressure Adjustment

The oil pressure on each unit has been preset at the factory during the load testing. Generally the oil pressure should not require adjustment once the unit is installed and in operation.

To adjust the unit to the proper oil pressure, remove the hex cap shown in **Figure 5-4**. Loosen the lock nut and turn the set screw clockwise to increase the pressure, or turn counterclockwise to decrease the pressure. Tighten the lock nut and replace the cap before reading the oil pressure. Always allow the unit to reach operating temperature before adjusting the oil pressure to the proper range. Set the oil pressure to 15 psig (103 kPa).

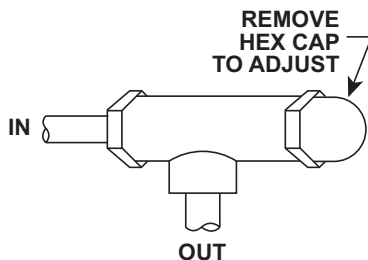

Figure 5-4 – Pressure Relief Valve

Oil Cooler

The supply line to the cooler can be connected to either hole. The fluid flowing through the heat exchanger should be sufficient to keep the oil temperature to the optimum operating range of 150-180°F (65-80°C). This temperature will ensure proper lubrication of the bearings and seals.

WARNING

If the unit is to be located outside or in a building where ambient temperatures can fall below freezing, then care must be taken to ensure the water or liquid used for cooling does not freeze and damage the blower. The oil cooler must be drained of liquid during downtime unless a re-circulating unit using a glycol mixture has been installed.

PIPING CONNECTIONS

WARNING

Pipe loading on the blower should be negligible as pipe loading can cause distortion of the blower. Use proper supports and pipe hangers to assure that there is no loading.

Remove the protective covers from the inlet and outlet ports and inspect for dirt and foreign material.

Inlet and outlet connections on all blowers are large enough to handle maximum volume with minimum friction loss. Maintain same-diameter piping. Do not support silencers by the blower. Avoid stress loads and bending moments.

Be certain all piping is clean internally before connecting to the blower. Place a 16-mesh wire screen backed with hardware cloth at or near the inlet connections for the first 50 hours of use until the system is clean. Clean the screen after 3 hours of operation and completely discard it once the system is clean, as it will eventually deteriorate and small pieces going into the blower can cause serious damage. A horizontal or vertical airflow piping configuration is easily achieved by rearranging the mounting feet position.

Hazards Associated With Hazardous Process Fluids

DANGER



It shall be the responsibility of the installer to ensure that piping is adequate, sealing between pipe joints is adequate for the process fluids and proper process and pressure protection devices are in place. It is also the responsibility of the installer to assure that process gasses are not vented in a manner that would be hazardous.

Refer to the manufacturer of the process media to assure that proper safety precautions are in place.

Blockage or Restriction

WARNING

Damage to the blower could occur if there is blockage in the inlet or outlet ports or piping. Care should be taken when installing the blower to assure that there are no foreign objects or restrictions in the ports or piping.

MOTOR DRIVES

Two drive connections commonly used are direct drive and V-belt drive.

Direct Coupled

When installing the motor directly to the blower, align the shafts to the coupling according to the coupling manufacturer's instructions. Blowers shipped with the motor directly coupled and mounted on a common base have been aligned prior to shipment. Further alignment is not normally necessary, but be sure to check the alignment and make adjustments if necessary prior to starting the blower.

Coupling halves must correctly fit the blower and drive shafts so that only light tapping is required to install each half. The two shafts must be accurately aligned. A direct-coupled blower and motor must be aligned with the two shafts having no more than 0.005 in. (13 mm) Total Indicator Reading (TIR). Make sure the face is aligned within 0.002 in. (0.05 mm).

Establish proper gap between coupling halves according to the coupling manufacturer's instructions with the motor armature. Proper gap will minimize the chance for end thrust on the blower shaft. Re-align and grease all direct-coupled base-mounted blowers after field installation.

V-Belts

If the motor and blower are V-belt connected, the sheaves on both the motor and blower shafts should be as close to the shaft bearings as possible. Blower sheave is not more than 1/4 in. (6.5 mm) from the blower drive end cover. The drive sheave is as close to the driver bearing as possible. Take care when installing sheaves on the blower and motor shafts. Make sure the face is accurately in line to minimize belt wear.

Adjust the belt tension to the manufacturer's specifications using a belt tension tester. Check new belts for proper tension after 24 hours of run time. When manufacturer data is not available, industry guidelines recommend 1/64 in. deflection for each inch of span (0.157 mm deflection per centimeter of span) at 8 – 10 lb (3.6 – 4.5 kg) of force in the center of the belt.

Insufficient tensioning is often indicated by slipping (squealing) at start-up. Do not use belt dressing on V-belts. Keep sheaves and V-belts free of oil and grease. Remove tension from belts if the drive is to be inactive for an extended period of time. For more specific information, consult the drive manufacturer. In a V-belt drive, the blower sheave must fit its shaft accurately, run true, and be mounted as close to the bearing housing as possible to minimize bearing loads.

A tight or driving fit will force the drive shaft out of its normal position and cause internal damage. A loose fit will result in shaft damage or breaking. Make sure the motor sheave fits correctly and is properly aligned with the blower sheave.

Adjust the motor position on its sliding base so that belt tension is in accordance with drive manufacturer's instructions. Always avoid excessive belt tension. Recheck tension after the first 10 hours of operation and periodically thereafter to avoid slippage and loss of blower speed.

Check the blower after installation and before applying power by rotating the drive shaft by hand.

If the drive shaft does not rotate freely:

- Look for uneven mounting, piping strain, excessive belt tension, or coupling misalignment
- Check the blower to make sure oil was added to the reservoirs

Setting V-Belt Tension

Proper belt tension is essential to long blower life. **Figure 5-5**, **Figure 5-6**, and the following procedure are provided to aid in field-adjusting V-belts (when the blower is so equipped) for maximum performance. A visual inspection of the V-belt drive should yield the appearance shown in **Figure 5-5**.

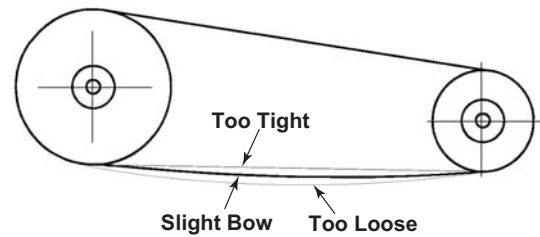

Figure 5-5 – General appearance of a V-belt drive

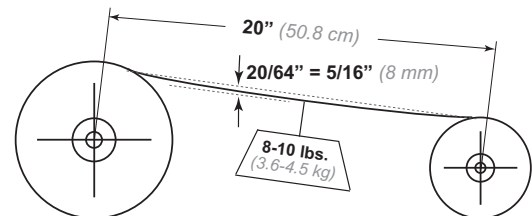

Figure 5-6 – Setting of proper tension for a V-belt drive

Factors outside the control of the belt tensioning system used on an individual blower package assembly, such as environmental factors and quality of the belts installed, may contribute to decreased belt life. Such factors can cause wear of the belts beyond the ability of the tensioning system to compensate.

As such, it is recommended to check belt tension monthly and make any manual adjustments found necessary.

1. Turn off and lock out power.
2. Remove the belt guard fasteners (if equipped).
3. Remove the belt guard.
4. Check and adjust the belt tension as necessary. Tension should be 1/64 in. deflection per inch of span (0.157 mm deflection per centimeter of span) between sheaves, with 8 – 10 lb (3.6 – 4.5 kg) force applied at the center point of the top section of belt.
5. Install the belt guard, making sure that all drive components are free of contact with the guard.
6. Install the belt guard fasteners that were removed in step 2.
7. Unlock the power and start the blower.
8. Resume normal operation.

V-Belt Troubleshooting

PROBLEM	POSSIBLE CAUSES	SOLUTION
Belts slip (sidewalls glazed)	Not enough tension	Replace belts; apply proper tension.
Drive squeals	Shock load	Apply proper tension.
	Not enough arc of contact	Increase center distance.
	Heavy starting load	Increase belt tension.
Belt(s) turned over	Broken cord caused by prying on sheave	Replace set of belts and install correctly.
	Overloaded drive	Redesign drive.
	Impulse loads	Apply proper tension.
	Misalignment of sheave and shaft	Re-align drive.
	Worn sheave grooves	Replace sheaves.
	Excessive belt vibration	Check drive design. Check equipment for solid mounting. Consider use of banded belts.
Mismatched belts	New belts installed with old belts	Replace belts in matched sets only.
Breakage of belt(s)	Shock loads	Apply proper tension; recheck drive.
	Heavy starting loads	Apply proper tension; recheck drive. Use compensator starting.
	Belt pried over sheaves	Replace set of belts correctly.
	Foreign objects in drives	Provide drive guard.
Rapid belt wear	Sheave grooves worn	Replace sheaves.
	Sheave diameter too small	Redesign drive.
	Mismatched belts	Replace with matched belts.
	Drive overloaded	Redesign drive.
	Belt slips	Increase tension.
	Sheaves misaligned	Align sheaves.
	Oil or heat condition	Eliminate oil. Ventilate drive.

Motor and Electrical Connections



WARNING

The motor and connections shall be protected to assure that product and environmental condensation does not come in contact with the electrical connections.

NOTICE

It is the responsibility of the installer to assure that the motor is in compliance with the latest edition of IEC 60204-1 and all electrical connections are performed per IEC 60204-1, this includes overcurrent protection.

Wire the motor and other electrical devices, such as solenoid valves and temperature switch, to the proper voltage and amperage as indicated on the nameplate of the component being wired. Turn the blower by hand after wiring is completed to determine that there are no obstructions and that the blower turns freely. Then, momentarily start the blower to check the direction of rotation.

Figure 4-2 shows direction of airflow in relation to rotor rotation. The airflow direction can be reversed by reversing the appropriate motor leads.

GENERAL

DANGER

The booster is not intended to be used with explosive products or in explosive environments unless fully approved by Tuthill Factory prior to the purchase of the product, designed specifically for the gas application.

WARNING



Do not operate without guards in place.



WARNING

Maximum operating speed: *Table 4-2* states the maximum operating speed in RPM (rotations per minute), the maximum pressure differential, maximum vacuum and maximum temperature rise. Do not exceed these limits.

Before starting the blower for the first time under power, recheck the installation thoroughly to reduce the likelihood of difficulties. Use the following checklist as a guide, but consider any other special conditions in your installation.

1. Be certain no bolts, rags, or dirt have been left in blower.
2. Be certain that inlet piping is free of debris. If an open outdoor air intake is used, be sure the opening is clean and protected by an inlet filter. This also applies to indoor use.
3. If installation is not recent, check blower leveling, drive alignment, belt tension, and tightness of all mounting bolts.
4. Be certain the proper volume of oil is in the oil reservoir chambers.
5. Be certain the driving motor is properly lubricated and connected through suitable electrical overload devices.
6. With electrical power off and locked out to prevent accidental starting, rotate the blower shaft several times by hand to make sure the blower is rotating freely. Unevenness or tight spots are indicators of a condition that should be corrected before progressing.
7. Check motor rotation by momentarily pushing the START button and then checking the flow direction of the blower. Reverse the motor connections if the flow is in the wrong direction.

Carry out initial operation under “no load” conditions by opening all valves and venting the discharge to the atmosphere, if possible. Then, start the motor briefly, listen for unusual noises, and make sure the blower coasts freely to a stop. If no problem appears, repeat this check and let the motor run slightly longer. If any questions exist, investigate before proceeding.

Assuming all tests are satisfactory, the blower will now be ready for continuous full-load operation. During the first several days, check periodically to make sure all conditions remain acceptable and

steady. These checks may be particularly important if the blower is part of a process system where conditions may vary. At the first opportunity, stop the blower and clean or remove the inlet filter. Also recheck leveling, coupling alignment or belt tension, and mounting bolts for tightness.

START-UP CHECKLIST

It is recommended that these start-up procedures be followed in sequence and checked off () in the boxes provided in any of the following cases.

<ul style="list-style-type: none"> • During initial installation • After any shutdown period 	<ul style="list-style-type: none"> • After maintenance work has been performed • After blower has been moved to a new location
DATES CHECKED:	<input type="text"/> <input type="text"/> <input type="text"/>
<input type="checkbox"/> <input type="checkbox"/> <input type="checkbox"/> <input type="checkbox"/>	Check the unit for proper lubrication. Proper oil level is critical. See Lubrication on page 14. See Recommended Lubricants on page 41 for information on acceptable lubricants for the product.
<input type="checkbox"/> <input type="checkbox"/> <input type="checkbox"/> <input type="checkbox"/>	Check the V-belt drive for proper belt alignment and tension.
<input type="checkbox"/> <input type="checkbox"/> <input type="checkbox"/> <input type="checkbox"/>	Carefully turn the rotors by hand to be certain they do not bind.



WARNING

Disconnect power. Make certain power is off and locked out before touching any rotating element of the blower, motor, or drive components.

<input type="checkbox"/> <input type="checkbox"/> <input type="checkbox"/> <input type="checkbox"/>	“Bump” the unit with the motor to check rotation (counterclockwise when facing the shaft) and to be certain it turns freely and smoothly.
<input type="checkbox"/> <input type="checkbox"/> <input type="checkbox"/> <input type="checkbox"/>	Start the unit and operate it for 30 minutes at no load. During this time, feel the cylinder for hot spots. If minor hot spots occur, see Troubleshooting on page 37.
<input type="checkbox"/> <input type="checkbox"/> <input type="checkbox"/> <input type="checkbox"/>	Apply the load and observe the operation of the unit for 1 hour.
<input type="checkbox"/> <input type="checkbox"/> <input type="checkbox"/> <input type="checkbox"/>	If minor malfunctions occur, discontinue operation and see Troubleshooting on page 37.

OPERATING

The upper temperature limit for blower operation is measured in the exhaust gas stream with a low-mass thermocouple. When this temperature limit switch is installed, as the temperature exceeds the predetermined temperature, the blower motor will stop and cannot be restarted until the temperature drops below the trip setting of the temperature switch.

DANGER

The booster is not intended to be used with explosive products or in explosive environments unless fully approved by Tuthill Factory prior to the purchase of the product, designed specifically for the gas application.

WARNING

Physical harm may occur if human body parts are in contact or exposed to the process vacuum. Assure that all connections are protected from human contact.

WARNING

If rated vacuum or pressure levels are exceeded, process fluids will migrate to other parts of the blower and system.

CAUTION



Do not touch hot surfaces.
Do not touch the blower while it is in operation and assure blower is cool when not in operation.

CAUTION

Use of a thermowell insulates the thermocouple. Invalid and delayed readings will result. This can result in ineffective protection devices.

NOTICE

The upper temperature limits are not intended for continuous operation. Consult with factory for detailed information assistance.

CAUTION

Do not stop the blower if there are high outlet pressures in the outlet piping. Unload the outlet piping prior to shutting down the blower.

Stop the blower by turning off the motor. Isolate the blower from the vacuum system and vent the blower to the atmosphere. Turn off the cooling water, if the blower is water cooled. Stop the backing pump. See the component instruction manual.

WATER-INJECTED BLOWERS

Water injected into the inlet of a blower operating on vacuum service will cool the blower. The water absorbs the heat of compression as it passes through the blower along with the air/gas being compressed. A blower cooled in this manner can operate safely at higher vacuums or higher inlet temperatures than an uncooled blower.

The amount of water required depends on the inlet air/gas temperature, inlet vacuum, water temperature, and maximum discharge temperature desired. Check with the factory or sales representative for more guidance.

Operation

1. Check the oil level in the sight glass of the blower and make sure all fittings are tight.
2. Check the water injection system to make sure water is available.
3. Operate the blower dry for 3 minutes at no load to check for correct rotation and smooth operation.
4. Turn the water on and adjust the flow as recommended for the individual blower. Make sure the water discharges freely from the outlet piping.
5. Apply vacuum and observe operation at the desired inlet condition.

Shutdown

It is possible to shut down the blower for brief periods by relieving the inlet vacuum, shutting off the water, and then stopping the blower.

To avoid rusting during a slightly longer shutdown period, operate the blower under a partial vacuum without the water injection, allowing the blower to heat within safe limits. The heat will tend to drive off residual moisture.

For extended shutdown, oil may be injected into the inlet of the heated blower just prior to shutting down the blower. The oil will provide a protective coating on the internal components. Make sure the water is completely shut off after shutdown.

Special coatings or platings are available to minimize rusting or corrosion in applications where blowers can remain wet.

Always use vertical-flow blowers with two-lobed, plugged rotors. Always orient the system with the blower intake at the top and discharge at the bottom.

CAUTION

Water injection can cause lime build-up on rotors. Check water supply for hardness. The use of water softeners, other chemicals, or distilled water may be necessary to prevent or remove this build-up. However, due to the wide variations in mineral content, pH, and chemical content of water that can be injected, Tuthill Vacuum & Blower Systems cannot be responsible for damage which may result should this build-up occur. Units should be inspected regularly to determine any problems.

NOTICE

For liquid injection other than water, consult the factory.

RECOMMENDED SHUTDOWN PROCEDURE TO MINIMIZE RISK OF FREEZING OR CORROSION

When an air piping system has high humidity or moisture, water condensation can occur after the blower is shut down and it begins to cool. Condensation creates an environment favorable to corrosion of the iron internal surfaces and to ice formation in cold weather. Both conditions can close the operating clearances, causing the blower to fail upon future start-up.

The following shutdown procedure minimizes the risk of moisture condensation, corrosion, and freezing.

NOTICE

Care must be taken not to overload or overheat the blower during this procedure.

1. Isolate the blower from the moist system piping, allowing the blower to intake atmospheric air. Operate the blower under a slight load, allowing the blower to heat within safe limits. The heat generated by the blower will quickly evaporate residual moisture.
2. For carpet cleaning applications, after the work is completed, allow the blower to run 3 – 5 minutes with the suction hose and wand attached. The suction hose and wand will provide enough load to the blower to evaporate the moisture quickly.
3. For extended shutdown, inject a small amount of a light lubricating oil such as 3-in-One® or a spray lubricant such as WD-40® into the inlet of the blower just before shutdown (*3-in-One and WD-40 are registered trademarks of WD-40 Company*). The lubricant will provide an excellent protective coating on the internal surfaces. If using a spray lubricant, take care to prevent the applicator tube from getting sucked into the blower. The applicator tube will damage the blower, likely to a degree where repair would be required.
4. If the blower is being taken out of commission for an extended period of time, **see Long-Term Storage on page 30.**

07

MAINTENANCE

GENERAL

Regular inspection of the blower and its installation, along with complete checks on operating conditions, will pay dividends in added life and usefulness. Also, service the drive per the manufacturer's instructions and lubricate the coupling or check the belt drive tension. Use thermometers and gauges to make sure that blower operating temperature and pressure remain within allowed limits.

DANGER



The blower and parts may contain hazardous media. Assure that pump and parts are evacuated of hazardous media prior to servicing.

CAUTION

The electrical service must be isolated and de-energized prior to maintenance. Apply appropriate procedures to assure electrical supply is de-energized and cannot be inadvertently energized during maintenance.

Assure piping and product is isolated prior to maintenance of blower. Apply appropriate procedures to assure piping and product is isolated and that inadvertent opening of valves cannot occur during maintenance.

CAUTION

During routine maintenance, inspect and assure that guards are in place and secure.

Pay special attention to lubrication of timing gears and bearings according to the information in ***Lubrication on page 14.***

When a blower is taken out of service, it may require internal protection against rusting or corrosion. The need for such protection must be a matter of judgment based on existing conditions as well as length of downtime. Under atmospheric conditions producing rapid corrosion, protect the blower immediately. ***See Long-Term Storage on page 30.***

REGULAR MAINTENANCE

A well-designed maintenance program will add years of service to the blower.

Check a newly installed blower frequently during the first month of operation, especially lubrication. With the blower at rest, check the oil level in both the gear (drive) end and free (non-drive) end of the blower and add oil as needed. Complete oil changes are recommended every 1,000 - 1,200 operating hours, or more frequently depending on the type of oil and operating temperature. Also change the oil more frequently if pumping corrosive vapors or where excessive operating temperatures are encountered. The following is recommended as a minimum maintenance program.

DAILY	WEEKLY	MONTHLY
<ol style="list-style-type: none"> 1. Check and maintain oil level, and add oil as necessary. 2. Check for unusual noise or vibration (See Troubleshooting on page 37). 	<ol style="list-style-type: none"> 1. Clean all air filters. A clogged air filter can seriously affect the efficiency of the blower and cause overheating and oil usage. 2. Check the relief valve to make sure it is operating properly. 	<ol style="list-style-type: none"> 1. Inspect the entire system for leaks. 2. Inspect the condition of the oil and change if necessary. 3. Check drive belt tension and tighten if necessary.

NOTICE

Oil levels should be checked every 24 hours of operation.

Proper oil drain schedules require oil be changed before the contaminant load becomes so great that the lubricating function of the oil is impaired or heavy disposition of suspended contaminants occurs. To check the condition of the oil, drain a sample into a clean container and check for the presence of water or solids. Slight discoloration of the oil should not necessitate an oil change.

SPARE PARTS

Should adjustments or replacement be needed, repairs can often be performed locally as described in this manual after obtaining the required parts. Personnel should have a good background of mechanical experience and be thoroughly familiar with the procedures outlined in this manual. For major repairs not covered in this manual, contact the nearest Tuthill Vacuum & Blower Systems service representative.

When ordering parts, supply the blower nameplate information, as well as the item number and parts description as per the parts lists and assembly drawings. Repair kits are available for all models. These kits contain all the seals, bearings, O-rings, locks, and special retaining screws necessary for an overhaul. For convenience when ordering parts, complete the **Operating Data Form** included on the inside back cover of this manual.

In developing a stock of spare parts, consider the following factors:

- The degree of importance in maintaining the blower in a “ready” condition
- The time lag in parts procurement
- Cost
- Shelf life (seals and O-rings)

FACTORY SERVICE AND REPAIR

With proper care, Tuthill Vacuum & Blower Systems blowers will give years of reliable service. The parts are machined to close tolerances and require special tools by mechanics who are skilled at this work. Should major repairs become necessary, contact the factory for the location of the nearest service facility.

NOTICE

Current regulations require Material Safety Data Sheet to be completed and forwarded to Tuthill Corporation on any unit being returned for any reason which has been handling or involved with hazardous gases or materials. This is for the protection of the employees of Tuthill Corporation who are required to perform service on this equipment. Failure to do so will result in service delays.

NOTICE

When returning a blower to the factory for repair under warranty, please note the factory will not accept any unit that arrives without authorization. Contact Customer Service for return authorization.

10. If possible, rotate the drive shaft by hand at least monthly to prevent seals from setting in one position.

LONG-TERM STORAGE

Any time the blower will be stored for an extended period of time, make sure it is protected from corrosion by following this procedure:

1. Spray the interior (lobes, housing, and end plates) with rust preventative. Repeat as conditions dictate and on an at least a yearly basis.
2. Fill both end covers completely full of oil.
3. Firmly attach a prominent tag stating that the end covers are full of oil and must be drained and refilled to proper levels before start-up.
4. Apply a rust-preventative grease to the drive shaft.
5. Spray all exposed surfaces, including the inlet and discharge flanges, with rust preventative.
6. Seal the inlet, discharge, and vent openings. It is not recommended that the blower be set in place, piped to the system, and allowed to remain idle for a prolonged amount of time. If any component is left open to the atmosphere, the rust preventative will escape and lose its effectiveness.
7. During storage, make sure the blower does not experience excessive vibration.
8. Attach a desiccant bag to one of the covers to prevent condensation from occurring inside the blower. Make sure any desiccant bag (or bags) is attached to the covers so that they will be removed before start-up of the blower.
9. Store the blower in an air conditioned and heated building if possible. If air conditioned and heated storage is not possible, make conditions as dry as possible.

DISASSEMBLY AND REASSEMBLY

DISASSEMBLY OF BLOWER

1. Drain lubrication, and disconnect or remove the external oil lines, filter, and cooler if applicable. Port fitting may also be removed. Match-mark all parts so they can be properly reinstalled to their original position when blower is reassembled.

Free End Disassembly

2. Remove cap screws and the oil pump mounting plate. It is not necessary to remove the oil pump from the plate unless the pump is to be replaced.
3. Support the free end cover with the lifting sling and remove cap screws. The cover flange has two tapped holes for jacking screws to assist in removal.
4. Remove cap screws, oil pump drive shaft, and oil slinger or slinger and spacer.
5. Remove retainer rings from both rotor shafts.

Gear End Disassembly (Series 17/19/46/55/57/81/82/86)

6. Remove flat-head socket screws. Use two jack screws and remove seal adapter. Tap out lip seal and discard O-ring.

Gear End Disassembly (Series 64/66/67/69)

7. Remove cap screws and water cooling hosing. Discard O-ring. Remove cap screws. Use two as jacket screws and remove seal housing. Tap out seal and discard O-ring. Remove mating ring portion of seal.
8. The gear end cover also has jacking screw holes but it must slide off a spherical bearing and two dowel pins. Use appropriate length screws and a support sling. **See Figure 13-2 on page 43** for a bearing installation tool, which can be helpful in cover removal.
9. Remove retainer ring and pull bearing from drive shaft.
10. Remove cap screws and the drive shaft. Jack screw holes are available for easy removal.
11. Remove cap screws and rotor shaft washer. On the top drive unit only, a slinger sandwiched between two washers is used on the lower rotor. Note the position before removing.
12. Remove the timing gears. Either gear may be used as the drive gear. Normally the solid gear (right-hand helix) will be the drive gear. The two-piece gear (gear shell and hub) will be the driven gear. Align the match marks and remove the cap screws in the two-piece gear. Using a suitable puller, remove the gear shell from the hub. Never use excessive force to remove. A slight rocking motion while pulling the gear will ensure that jamming has not occurred. If jamming does occur, tap gear back on until free moving and recheck location of the timing

marks. Using the same puller, remove the gear hub and solid gear.

13. Remove cap screws and retainer rings.

End Plate and Rotor Disassembly

14. Stand blower on its free end on 4 in. × 4 in. (102 mm × 102 mm) blocks and remove mounting feet.
15. Remove the end plate cap screws. The end plate with the bearing must be pulled from the rotor shafts. Use two fixtures as shown in **Figure 13-2 on page 43**. Secure each fixture to the bearing retainer bolt holes and apply pressure to the end of the rotor shaft with the center screws or the nuts on the threaded rod. The pressure must be applied equally to each shaft. When the end plate is removed, tap out the bearing seals. Remove retainer rings and tap out labyrinth seals.
16. Install the end plate to the housing without bearings, and secure with six cap screws. Turn the blower over and support with blocks under the gear end plate.
17. Remove cap screws, oil retainer ring, and end plate cap screws. Remove the end plate using the same tool used on the gear end. Remove the bearings and seals. Discard all O-rings.
18. Lift the rotors out of the housing. Unbolt the gear end plate and lift off the housing.
19. Clean, deburr, polish, and inspect all parts for wear and serviceability.

NOTE: Check orifice in end plates and gear cover for blockage on units with external oil lines.

ASSEMBLY OF BLOWER

The assembly procedure is generally the same for all series, but notations are made where there are differences.

When sealing the joints between the housing, end plates, end covers, and port fittings, an RTV Silicone sealer or the equivalent is required. On some units, O-rings are used to seal between the housing and the end plates. Dowel pins are used to locate the end plates, housing, and drive end cover in proper location relative to each other. Be sure the dowel pins are in place.

It is recommended that only factory parts be used when repairing a unit. This will ensure the proper operating clearance needed for your unit to operate properly.

On lip seal units, properly polish the seal journals to remove any scratches or burrs. Failure to polish will result in leakage and/or damage to the seals.

Preparation of End Plates for Assembly

1. Make sure all parts are clean and free of nicks or burrs caused by disassembly. **See Figure 8-2 and Figure 8-3 on page 34** for dimension of seal pressing tools.
2. Position end plates with bearing bores up. Press labyrinth seals into seal bores of both end plates. Install retainer ring.

Lip Seal Installation (Series 17/19/46/86)

3. Apply a thin coat of sealer on the outside diameter of the seal. Press into the seal bore with the lip seal facing toward the bearing. Lubricate the lip seal with grease only.

Lip Seal Installation (Series 55/57/64/66/67/69/81/82)

- Follow instructions for the lip seal but do not grease. Install the carbon up. On the free end plate, be sure the spacer is in place before installing the seal. If no press is available, use the bearing pressing plate. **See Figure 13-2 on page 43.** Make sure no sealer is left on the carbon. Clean with soft tissue and cleaning agent (acetone) if necessary. Failure to remove will result in leakage.

Gear End Assembly

- Place the free end plate with flat side up on a pair of 4 in. × 4 in. (102 mm × 102 mm) blocks. The end plate must be blocked so rotor shafts will not touch the floor. Do not install the O-ring at this time.
- Set the housing in place, making sure the dowel pins are installed. Do not bolt at this time.
- Lay two pieces of shim 1/8 in. (3 mm) thick on the end plate at the bottom of the housing.
- Set each rotor into position in the housing with the gear end (long shaft) up. Face keyways in the direction shown in **Figure 8-1.** This will position the rotors so they will match the keyways in the gear.

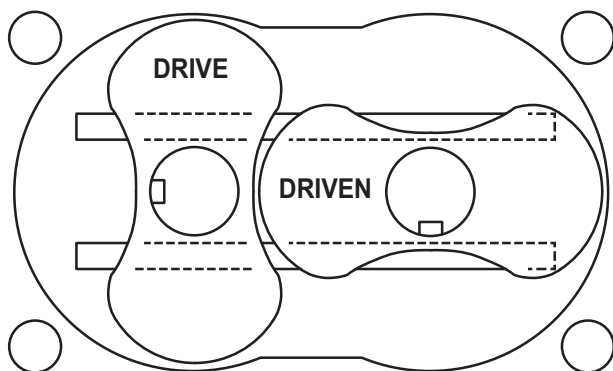

Figure 8-1 – Keyways

- Grease four O-rings and install in the gear end plate. Run a continuous bead of sealer, about 1/8 in. (3 mm) wide around the perimeter of the housing, encircling each bolt hole and dowel pin. This is not required if O-rings have been furnished (mechanical seal units only).
- Bolt the housing to the gear end plate and tighten bolts. Use six bolts, equally spaced, and secure the free end plate against shims at the bottom end of the rotors. Hand-tighten only.

End Plate Installation (Series 55/57/64/66/67/69/81/82)

- Clean the lapped surfaces of the mating rings with soft tissue and acetone, taking care not to nick or scratch the surface. Place a few drops of oil on the surface and the O-ring. Carefully slide over the rotor shaft and align the slot in the mating ring with the spring pin in the rotor shaft.
- Coat the rotors with a light grease and press the bearing on the shaft. The bearing manufacturer numbers and/or the acid dot (inner race) should be toward the gears. Use a bearing installation tool shown in **Figure 13-2 on page 43.**
- Loosen bolts holding the free end plate to the housing, and then install the bearing retainer rings and secure with cap screws. Check the clearances between rotor lobes and gear end plate. If clearances are not within specification, recheck parts to find the cause of the improper clearances before proceeding.
- Install the key in the rotor shaft and make sure it fits tightly. Coat the shaft and the keys with grease.

If gears are being replaced, disassemble the new two-piece gear before proceeding.

15. Heat the solid gear and the hub of the two-piece gear to 350°F (177°C). Install the solid gear and hub onto the rotor shafts. Secure with washers and cap screws. Do not install the gear shell at this time. Allow the hub and solid gear to cool.

Free End Assembly

16. Retighten the six free end plate screws by hand. Turn the unit over and support it on blocks with the free end up.
17. Remove the six screws and put jack screws in holes provided in the flange of the end plate and remove the end plate. Take out the 1/8 in. (3 mm) shims and check clearance between the end of the lobes and the housing using a flat bar and feeler gauges or a depth micrometer.
18. Install the four O-rings, apply sealant to the housing or O-ring, reinstall end plate and secure with cap screws.

Free End Assembly (Series 55/57/64/66/67/69/81/82)

19. Install seal mating rings using the procedure in ***Gear End Assembly on page 33*** (step 10).
20. Install bearing using the procedure in ***End Plate Installation (Series 55/57/64/66/67/69/81/82) on page 33*** (step 12). Install bearing retainer rings, oil retainer rings and cap screws.
21. Install mounting feet with cap screws and stand unit on its feet. For horizontal flow units, you may prefer to lay unit on its side with the drive gear to the left. This will make it easier to take interlobe readings later.
22. Install the gear shell to the hub, making sure the timing shims are in place and bolts are tight.

NOTICE

As the second gear is installed, the helical teeth will cause the rotor to turn. Unless the rotors are in an open position, they will jam. To avoid jamming, rotate the installed gear until the timing mark is at the center and the second gear with its timing mark is matched to the timing mark on the installed gear.

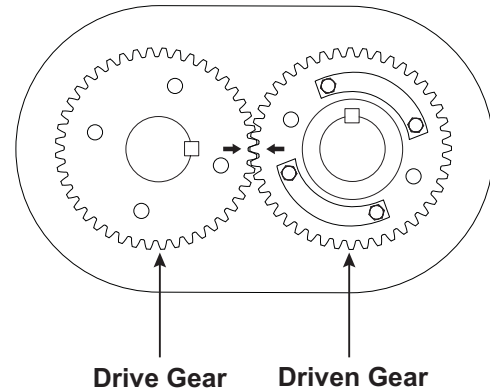

Figure 8-2 – Timing Marks Matched

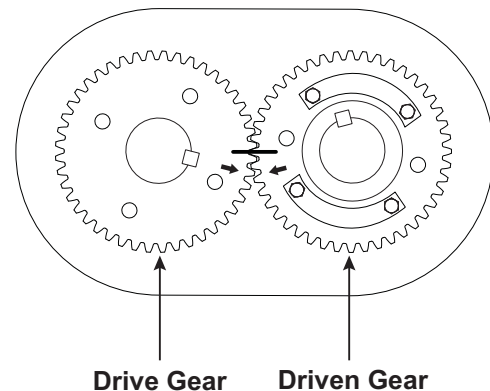

Figure 8-3 – Timing Marks Advanced 3 Teeth (Reference Marks Aligned)

Adjusting Interlobe Clearance

23. The outer gear shell is fastened to the inner hub with four cap screws and located with two dowel pins. Adding and removing shims between the gear shell and the inner hub moves the gear shell axially. The helix causes the gear to rotate, which changes the clearance between the rotor lobes. Adding 0.030 in. (0.762 mm) shim thickness will change the rotor lobe clearance by approximately 0.009 in. (0.229 mm).
24. The timing shim is formed from a number of 0.003 in. (0.0762 mm) shims which have been laminated together. Easily peel them apart as necessary.

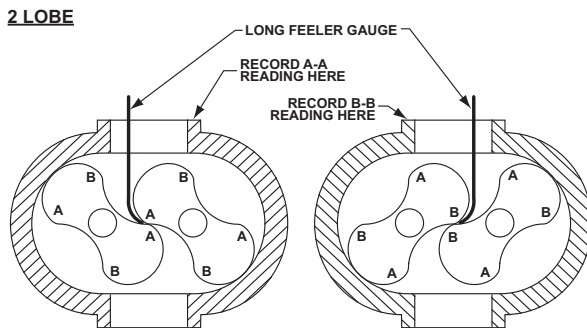

Figure 8-4 – Checking Rotor Interlobe Clearance

25. Use feeler gauges to check the clearance at AA (right-hand reading) and BB (left-hand reading) (see **Figure 8-4**). The clearance should be adjusted so it is as equal between all lobes as possible, usually between 0.002 to 0.003 in. (0.0508 to 0.0762 mm). For best results, use feeler gauges no larger than 0.006 in. (0.1524 mm).

Example: If AA reading is 0.020 in. (0.508 mm) and BB reading is 0.008 in. (0.2032 mm), removing 0.021 in. (0.5334 mm) shims will change the reading by 0.006 in. (0.1524 mm). AA should read 0.014 in. (0.3556 mm) and BB should read 0.014 in. (0.3556 mm). Remember to place timing marks on the center and match when removing or installing a gear.

Complete Drive End Assembly

26. Clean and remove all burrs from the mating surfaces of the gear and drive shaft. Install cap screws. Check drive shaft run-out at the seal. Do not exceed 0.003 in. (0.0762 mm) T.I.R.
27. Install drive shaft bearing and retainer ring. If using a top drive unit, install oil slinger and washer at this time.
28. To aid in the installation of the cover, use a tool as shown in **Figure 13-2 on page 43**, which should be made to hold the outer race of the bearing square with the shaft. Put sealer on the end plate and slide the cover over the tool and secure with cap screws.

Complete Drive End Assembly (Series 17/19/46/55/57/81/82/86)

29. Press seal into adapter. Grease seal and O-ring and install on shaft. Secure with flat head screws.

Complete Drive End Assembly (Series 17/19/46/55/57/81/82/86)

30. Seal into seal housing and install O-ring. Clean carbon surface and lapped surface of mating ring with a soft tissue and acetone. Place a few drops of oil on the mating ring and O-ring and carefully slide over shaft aligning slot with pin. Install retainer ring. Install seal housing and secure with cap screws. Grease and install O-rings. Install water cooling housing.

Complete Free End Assembly (Series 17/46/57/64/67/81)

31. Install oil pump drive shaft. Oil slinger and secure with cap screws. Put sealer on the end plate and install cover.

Complete Free End Assembly (Series 19/55/66/69/82/86)

32. Install oil pump drive shaft, oil slinger, and secure with cap screws. Put sealer on the end cover. Grease and install O-ring. Align oil pump coupling with slot in drive shaft and install plate. Secure with cap screws. If oil pump is being replaced, install new O-ring.
33. Apply sealer to housing and install port fittings. Install cooler, oil filter, and external oil lines on the unit with lube system.

SPECIAL INSTRUCTIONS FOR GEAR HEAD BLOWERS

1. On units furnished with gear head drives (ratio), follow disassembly procedures up to and including step 6 **on page 31**. Then remove the cover end plate cap screws and nuts using jack screw holes provided, remove the drive end cover and tap out the lip seal.
2. Remove the gear housing cap screws and gear housing using jack screw holes.
3. The drive shaft gear and bearing assembly can now be tapped free from the housing. Remove retainer rings and press shaft from bearing and gear.
4. Tap out mating gear assembly and disassemble in the same manner.
5. Remove stub shaft cap screws and stub shaft.
6. Continue blower disassembly (**see Gear End Disassembly (Series 64/66/67/69) on page 31**, step 11).
7. Use reverse order to reassemble.

TROUBLESHOOTING

Although Tuthill Vacuum & Blower Systems blowers are well designed and manufactured, problems may occur due to normal wear and the need for readjustment. The following chart lists symptoms that may occur along with probable causes and remedies.

SYMPTOM	PROBABLE CAUSE	REMEDIES
Loss of oil	Gear housing not tightened properly	Tighten gear housing bolts.
	Lip seal failure	Disassemble and replace lip seal.
	Insufficient sealant	Remove gear housing and replace sealant. See Disassembly and Reassembly on page 31.
	Loose drain plug	Tighten drain plug.
Excessive bearing or gear wear	Improper lubrication	Correct oil level. Replace dirty oil. See Lubrication on page 14.
	Excessive belt tension	Check belt manufacturer's specifications for tension and adjust accordingly.
	Coupling misalignment	Check carefully. Re-align if necessary.
Lack of volume	Slipping belts	Check belt manufacturer's specifications for tension and adjust accordingly.
	Worn lobe clearances	Check for proper clearances. See Assembly Clearances on page 39.
	Speed too low	Increase blower speed within limits.
	Obstruction in piping	Check system to ensure an open flow path.
Knocking	Blower out of time	Re-time.
	Distortion due to improper mounting or pipe strains	Check mounting alignment and relieve pipe strains.
	Excessive pressure differential	Reduce to manufacturer's recommended pressure. Examine relief valve and reset if necessary.
	Worn gears	Replace timing gears. See Disassembly and Reassembly on page 31.

SYMPTOM	PROBABLE CAUSE	REMEDIES
Excessive blower temperature	Too much or too little oil in gear reservoir	Check oil level. See Lubrication on page 14.
	Too low operating speed	Increase blower speed within limits.
	Clogged filter or silencer	Remove cause of obstruction.
	Excessive pressure differential	Reduce pressure differential across the blower.
	Elevated inlet temperature	Reduce inlet temperature.
	Worn lobe clearances	Check for proper clearances. See Assembly Clearances on page 39.
Rotor end or tip drag	Insufficient assembled clearances	Correct clearances. See Assembly Clearances on page 39.
	Case or frame distortion	Check mounting and pipe strain.
	Excessive operating pressure	Reduce pressure differential.
	Excessive operating temperature	Reduce pressure differential or reduce inlet temperature.
Vibration	Belt or coupling misalignment	Check carefully. Re-align if necessary.
	Lobes rubbing	Check cylinder for hot spots, and then check for lobe contact at these points. Correct clearances. See Assembly Clearances on page 39.
	Worn bearings or gears	Check condition of gears and bearings. Replace if necessary.
	Unbalanced or rubbing lobes	Possible build-up on casing or lobes, or inside lobes. Remove build-up and restore clearances.
	Driver or blower loose	Check mounting and tighten if necessary.
	Piping resonance	Check pipe supports, check resonance of nearby equipment, and check foundation.

ASSEMBLY CLEARANCES

MODEL	GEAR END	FREE END	INTERLOBE	TIP-DOWEL	TIP-PORT
9016	0.007 – 0.010 in. (0.18 – 0.25 mm)	0.012 – 0.017 in. (0.30 – 0.43 mm)	0.013 – 0.018 in. (0.33 – 0.46 mm)	0.009 – 0.013 in. (0.23 – 0.33 mm)	0.013 – 0.018 in. (0.33 – 0.46 mm)
9020	0.007 – 0.010 in. (0.18 – 0.25 mm)	0.015 – 0.020 in. (0.38 – 0.51 mm)	0.013 – 0.018 in. (0.33 – 0.46 mm)	0.009 – 0.013 in. (0.23 – 0.33 mm)	0.013 – 0.018 in. (0.33 – 0.46 mm)
9027	0.007 – 0.010 in. (0.18 – 0.25 mm)	0.020 – 0.025 in. (0.51 – 0.63 mm)	0.013 – 0.018 in. (0.33 – 0.46 mm)	0.009 – 0.013 in. (0.23 – 0.33 mm)	0.013 – 0.018 in. (0.33 – 0.46 mm)
9036	0.007 – 0.010 in. (0.18 – 0.25 mm)	0.029 – 0.034 in. (0.76 – 0.86 mm)	0.013 – 0.018 in. (0.33 – 0.46 mm)	0.009 – 0.013 in. (0.23 – 0.33 mm)	0.013 – 0.018 in. (0.33 – 0.46 mm)

11

TORQUE CHART

Data shown represents “wet” torque values.

PART DESCRIPTION	TORQUE
CAP SCREW 10-32UNF	3 ft-lb (4 N-m)
CAP SCREW 1/4"-20UNC GR5	6 ft-lb (8 N-m)
CAP SCREW 5/16"-18UNC GR5	13 ft-lb (17 N-m)
CAP SCREW 3/8"-16UNC GR5	23 ft-lb (31 N-m)
CAP SCREW 1/2"-13UNC GR5	57 ft-lb (77 N-m)
CAP SCREW 5/8"-14UNC GR5	113 ft-lb (153 N-m)
CAP SCREW 3/4"-10UNC GR5	200 ft-lb (271 N-m)
CAP SCREW M12-1.75	70 ft-lb (94 N-m)

RECOMMENDED LUBRICANTS

RECOMMENDED LUBRICANTS FOR ROTARY BLOWERS AND VACUUM BOOSTERS

RECOMMENDED SYNTHETIC BASED LUBRICANTS FOR BLOWERS				
AMBIENT TEMPERATURE	TUTHILL	VISCOSITY GRADE	ISO 100	ISO 150
0° to 32°F (-18° to 0°C)	PneuLube™ (ISO 100)	Specific Gravity 16° C (62° F)	0.859	0.865
32° to 90°F (0° to 32°C)		Viscosity 40° C (104° F)	91.8 cSt	142.7 cSt
90° to 120°F* (32° to 50°C)		Viscosity 100° C (212° F)	13.1 cSt	18.0 cSt
		Viscosity Index	142	140
		Pour Point	-51° C (-60° F)	-51° C (-60° F)
		Flash Point	246° C (475° F)	246° C (475° F)
		Copper Corrosion Rating	1A	1A
RECOMMENDED SYNTHETIC BASED, FOOD GRADE LUBRICANTS FOR BLOWERS				
AMBIENT TEMPERATURE	LUBRICANT MEETING U.S. FDA REGULATION 21 CFR 178.3570 GOVERNING PETROLEUM PRODUCTS WHICH MAY HAVE INCIDENTAL CONTACT WITH FOOD, AND USDA H1 REQUIREMENTS		LUBRICANT MEETING U.S. FDA REGULATIONS 21 CFR 172.878 AND 178.3620(A) FOR DIRECT AND INDIRECT FOOD CONTACT	
0° to 32°F (-18° to 0°C)	PneuLube™ FG (ISO 100)		CONSULT FACTORY	
32° to 90°F (0° to 32°C)				
90° to 120°F* (32° to 50°C)				

Recommended Lubricants

RECOMMENDED LUBRICANTS FOR M-D VACUUM BOOSTERS	
REQUIREMENTS	
<ul style="list-style-type: none"> • Suitable for high vacuum service • 100 cSt @ 40°C • Vapor pressure of 1 micron or less @ 70°F (21°C) • Straight mineral (no additives) or PAO synthetic oil 	
RECOMMENDED GREASE FOR CP BLOWERS:	
TUTHILL	
Tuthill PneuLube™ NLGI #2 premium grade, petroleum base lithium grease.	Food Grade HTEP grease, NLGI No. 2 grade. Must meet all requirements of FDA Regulation 21 CFR 178.3570 (the former USDA H-1 approval requirements) for lubricants having incidental contact with food.
* For higher ambient temperatures, please consult the factory.	
RECOMMENDED OIL FOR OXYGEN-ENRICHED SERVICE	
Blowers used in oxygen-enriched service should use only non-flammable, PFPE synthetic lubricant. Blowers used in hydrogen service should use only PneuLube synthetic oil. Tuthill Vacuum & Blower Systems cannot accept responsibility for damage to seals, O-rings and gaskets caused by use of synthetic lubricants not recommended by Tuthill Vacuum and Blower Systems.	

* For higher ambient temperatures, please consult the factory.

** Blowers used in oxygen-enriched service should use only Castrol Brayco 1726 Plus non-flammable, PFPE synthetic lubricant. Blowers used in hydrogen service should use only PneuLube synthetic oil. Tuthill Vacuum & Blower Systems cannot accept responsibility for damage to seals, O-rings and gaskets caused by use of synthetic lubricants not recommended by Tuthill Vacuum & Blower Systems.

SPECIAL TOOL DRAWINGS

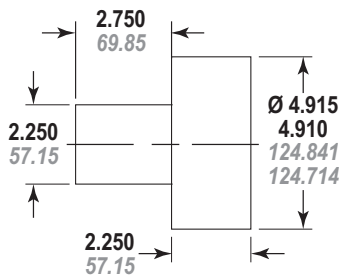
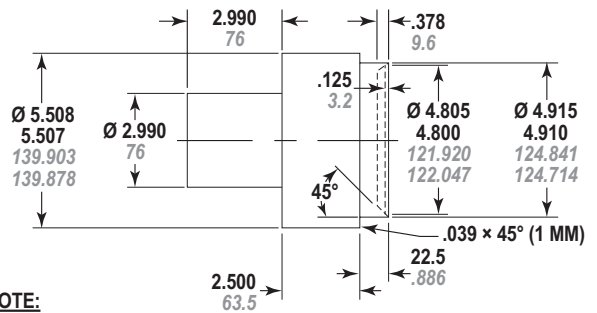

Figure 13-1 – Labyrinth Seal Installation Tool



NOTE:

All dimensions are shown in Inches and millimeters.

Figure 13-3 – Seal Installation Tool

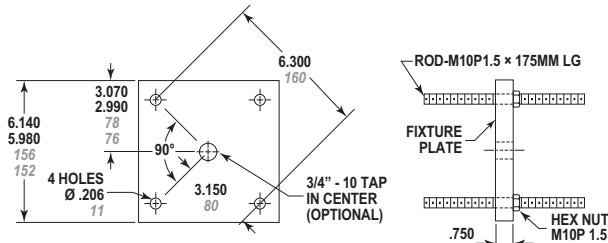
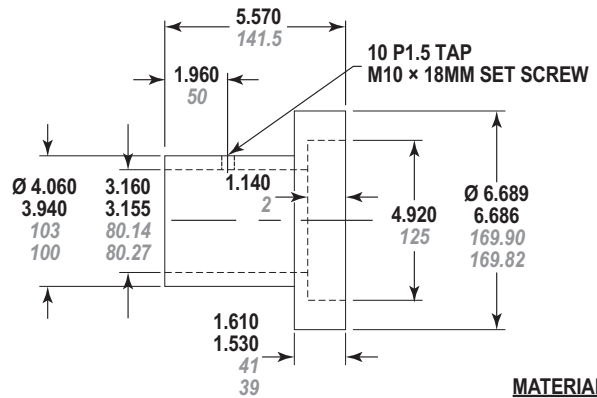

Figure 13-2 – Bearing Installation Tool



MATERIAL:

MILD STEEL

Figure 13-4 – Alignment Tool for Drive Shaft Bearing

PARTS LIST

Parts List for Model 9000 17/46 Series Blowers

ITEM NO.	PART DESCRIPTION	17 QTY	46 QTY
1	Mechanical Seal Rotor	2	2
3	Housing	1	1
4	End Plate	2	2
6	Drive End Cover	1	1
7	Free End Cover	1	1
8	Timing Gear Set	1	1
9	Bearing, Drive End	2	2
10	Bearing, Free End	2	2
12	Lip Seal	5	5
14	Retainer	2	2
15	Retainer	2	2
16	Timing Gear Shim	2	2
20	Slinger	1	1
22	Dowel Pin	6	6
23	Drive Shaft Key	1	1
24	Gear Key	2	2
25	Rotor Shaft Washer	3	2
26	Cap Screw	96	96
29	Cap Screw	8	8
31	Magnetic Plug	2	2
37	Breather	1	1
38	Port	2	2
42	Nameplate	1	1
45	Drive Shaft	1	1
46	Seal Adapter	1	1
47	Retaining Ring	1	1
50	Roller Bearing	1	1
51	Seal	4	4
62	Cap Screw	16	16
62	Cap Screw	4	4
66	Cap Screw	4	4
69	Cap Screw	4	4
70	Oil Sight Gauge	1	1

ITEM NO.	PART DESCRIPTION	17 QTY	46 QTY
92	O-Ring	1	1
109	Pipe Plug	1	1
174	Pipe Plug	12	10
195	Lifting Lug	2	2
196	Cap Screw	8	4
197	Spacer	1	1
199	O-Ring	2	2
219	Retaining Ring	4	4
220	Retaining Ring	2	2
224	Oil Retainer	1	1
225	Cap Screw	4	4
226	Lock Washer	4	4
232	Pipe Plug	4	4
233	O-Ring	8	8
304	Mounting Foot	4	4
307	Cap Screw	8	8
339	Straight Thread Plug	1	1
395	Oil Slinger	1	-

NOTES:

- QUANTITIES SHOWN ARE MAXIMUM VALUES. QUANTITIES MAY VARY BETWEEN BLOWER.

**PARTS KITS ARE AVAILABLE AS FOLLOWS:
17/46 – P/N 29218**

Parts List for Model 9000 19/86 Series Blowers

ITEM NO.	PART DESCRIPTION	19 QTY	86 QTY
1	Mechanical Seal Rotor	2	2
3	Housing	1	1
4	End Plate	2	2
6	Drive End Cover	1	1
7	Free End Cover	1	1
8	Timing Gear Set	1	1
9	Bearing, Drive End	2	2
10	Bearing, Free End	2	2
13	Lip Seal	5	5
14	Retainer	2	2
15	Retainer	2	2
16	Timing Gear Shim	2	2
20	Slinger	1	1
22	Dowel Pin	8	8
23	Drive Shaft Key	1	1
24	Gear Key	2	2
25	Rotor Shaft Washer	2	2
26	Cap Screw	96	96
29	Cap Screw	8	8
31	Magnetic Plug	2	2
37	Breather	1	1
38	Port	2	2
42	Nameplate	1	1
45	Drive Shaft	1	1
46	Seal Adapter	1	1
47	Retaining Ring	1	1
50	Roller Bearing	1	1
51	Seal	4	4
52	Oil Filter Spacer	1	1
62	Cap Screw	16	16
62	Cap Screw	4	4
66	Cap Screw	4	4
69	Cap Screw	4	4
70	Oil Sight Gauge	1	1
92	O-Ring	1	1
102	Pipe, 1/4 NPT	5	5
105	Pipe, 1/2 - STL	1	1
109	Pipe Plug	2	2
117	Lock Washer	3	3
124	Spin-On Oil Filter	1	1
136	Lock Washer	6	6
144	Oil Pump	1	1
147	Tube	1	1
148	Tube Connector	6	6
149	Pipe	1	1
150	Tube	1	1
155	Tube Elbow	1	1
161	Tube	2	2
162	Tube	1	1
163	Tube Elbow	6	6
165	Tube Connector	1	1
167	Pipe	1	1
168	Reducer Bushing	1	1
172	Reducer Bushing	1	1

ITEM NO.	PART DESCRIPTION	19 QTY	86 QTY
173	Heat Exchanger	1	1
174	Pipe Plug	8	6
179	Tube, Al	1	1
190	Tube, Al	1	1
195	Lifting Lug	2	2
196	Cap Screw	4	4
199	O-Ring	2	2
219	Retaining Ring	4	4
220	Retaining Ring	2	2
224	Oil Retainer	1	1
225	Cap Screw	4	4
226	Lock Washer	4	4
228	Cap Screw	3	3
232	Pipe Plug	4	4
233	O-Ring	8	8
252	Cap Screw	4	4
253	Cap Screw	6	6
254	Cap Screw	2	2
255	Roll Pin	2	2
257	Cross NPT	1	1
259	Reducing Tee	4	4
261	Reducing Elbow	1	1
262	Gauge, Liquid-Filled	1	1
265	Bypass Relief Valve	1	1
267	Oil Pump Shaft	1	1
270	Adapter	1	1
275	Oil Pump Coupling	1	1
285	Pipe	1	1
290	Reducer Bushing	1	1
304	Mounting Foot	4	4
307	Cap Screw	8	8
312	Tee	1	1
313	Adapter	1	1
325	O-Ring	1	1
336	Orifice Fitting	5	5
339	Straight Thread Plug	1	1
349	Pipe	1	1
351	Pipe	4	4
354	Reducer Bushing	5	5
360	Oil Filter Threaded Tube	1	1
361	O-Ring	1	1
368	Tee	1	1
369	Tube, Al	2	2
398	Reducer Coupling	1	1

NOTES:

- QUANTITIES SHOWN ARE MAXIMUM VALUES. QUANTITIES MAY VARY BETWEEN BLOWER.

**PARTS KITS ARE AVAILABLE AS FOLLOWS:
19/86 – P/N 29218**

Parts List for Model 9000 55/82 Series Blowers

ITEM NO.	PART DESCRIPTION	55 QTY	82 QTY
1	Mechanical Seal Rotor	2	2
3	Housing	1	1
4	End Plate	2	2
6	Drive End Cover	1	1
7	Free End Cover	1	1
8	Timing Gear Set	1	1
9	Bearing, Drive End	2	2
10	Bearing, Free End	2	2
13	Lip Seal	1	1
14	Retainer	2	2
15	Retainer	2	2
16	Timing Gear Shim	2	2
20	Slinger	1	1
22	Dowel Pin	8	8
23	Drive Shaft Key	1	1
24	Gear Key	2	2
25	Rotor Shaft Washer	2	2
26	Cap Screw	88	96
29	Cap Screw	8	8
31	Magnetic Plug	2	2
37	Breather	1	1
38	Port	2	2
42	Nameplate	1	1
45	Drive Shaft	1	1
46	Seal Adapter	1	1
47	Retaining Ring	1	1
50	Roller Bearing	1	1
51	Seal	4	4
52	Oil Filter Spacer	1	1
54	Mechanical Seal	4	4
55	Spacer	2	2
62	Cap Screw	16	16
62	Cap Screw	4	4
66	Cap Screw	4	4
69	Cap Screw	4	4
70	Oil Sight Gauge	1	1
92	O-Ring	1	1
102	Pipe, 1/4 NPT	5	5
105	Pipe, 1/2 - STL	1	1
109	Pipe Plug	2	2
117	Lock Washer	3	3
121	Pipe Plug	3	3
124	Spin-On Oil Filter	1	1
136	Lock Washer	6	6
144	Oil Pump	1	1
147	Tube	1	1
148	Tube Connector	6	6
149	Pipe	1	1
150	Tube	1	1
155	Tube Elbow	1	1
161	Tube	2	2
162	Tube	1	1
163	Tube Elbow	6	6
165	Tube Connector	1	1
167	Pipe	1	1
168	Reducer Bushing	1	1

ITEM NO.	PART DESCRIPTION	55 QTY	82 QTY
172	Reducer Bushing	1	1
173	Heat Exchanger	1	1
174	Pipe Plug	10	10
176	O-Ring	10	2
179	Tube, Al	2	1
190	Tube, Al	1	1
195	Lifting Lug	2	2
196	Cap Screw	4	4
199	O-Ring	4	2
219	Retaining Ring	4	4
220	Retaining Ring	4	2
224	Oil Retainer	2	1
225	Cap Screw	4	4
226	Lock Washer	4	4
228	Cap Screw	4	3
232	Pipe Plug	4	4
233	O-Ring	8	8
252	Cap Screw	8	4
253	Cap Screw	6	6
254	Cap Screw	6	2
256	Tube Elbow	2	2
257	Cross NPT	2	1
259	Reducing Tee	4	4
261	Reducing Elbow	4	1
262	Gauge, Liquid-Filled	1	1
265	Bypass Relief Valve	1	1
267	Oil Pump Shaft	1	1
270	Adapter	1	1
275	Oil Pump Coupling	1	1
285	Pipe	1	1
290	Reducer Bushing	1	1
300	Roll Pin	4	4
304	Mounting Foot	4	4
307	Cap Screw	8	8
312	Tee	1	1
313	Adapter	1	1
325	O-Ring	1	1
336	Orifice Fitting	5	5
339	Straight Thread Plug	1	1
349	Pipe	1	1
351	Pipe	4	4
354	Reducer Bushing	5	5
360	Oil Filter Threaded Tube	1	1
361	O-Ring	1	1
368	Tee	1	1
369	Tube, Al	2	2
398	Reducer Coupling	1	1

NOTES:

- QUANTITIES SHOWN ARE MAXIMUM VALUES. QUANTITIES MAY VARY BETWEEN BLOWER.

**PARTS KITS ARE AVAILABLE AS FOLLOWS:
55/82 – P/N 29241**

Parts List for Model 9000 57/81 Series Blowers

ITEM NO.	PART DESCRIPTION	57 QTY	81 QTY
1	Mechanical Seal Rotor	2	2
3	Housing	1	1
4	End Plate	2	2
6	Drive End Cover	1	1
7	Free End Cover	1	1
8	Timing Gear Set	1	1
9	Bearing, Drive End	2	2
10	Bearing, Free End	2	2
13	Lip Seal	1	1
14	Retainer	2	2
15	Retainer	2	2
16	Timing Gear Shim	2	2
20	Slinger	1	1
22	Dowel Pin	6	6
23	Drive Shaft Key	1	1
24	Gear Key	2	2
25	Rotor Shaft Washer	3	2
26	Cap Screw	96	88
29	Cap Screw	8	8
31	Magnetic Plug	2	2
37	Breather	1	1
38	Port	2	2
42	Nameplate	1	1
45	Drive Shaft	1	1
46	Seal Adapter	1	1
47	Retaining Ring	1	1
50	Roller Bearing	1	1
51	Seal	4	4
54	Mechanical Seal	4	4
55	Spacer	2	2
62	Cap Screw	16	16
62	Cap Screw	4	4
66	Cap Screw	4	4
69	Cap Screw	4	4

ITEM NO.	PART DESCRIPTION	57 QTY	81 QTY
70	Oil Sight Gauge	1	1
92	O-Ring	1	1
109	Pipe Plug	1	1
121	Pipe Plug	2	2
174	Pipe Plug	14	14
176	O-Ring	2	2
195	Lifting Lug	2	2
196	Cap Screw	8	4
197	Spacer	1	1
199	O-Ring	2	2
219	Retaining Ring	4	4
220	Retaining Ring	2	2
224	Oil Retainer	1	1
225	Cap Screw	4	4
226	Lock Washer	4	4
232	Pipe Plug	4	4
233	O-Ring	8	8
300	Roll Pin	4	4
304	Mounting Foot	4	4
307	Cap Screw	8	8
339	Straight Thread Plug	1	1
395	Oil Slinger	1	-

NOTES:

- QUANTITIES SHOWN ARE MAXIMUM VALUES. QUANTITIES MAY VARY BETWEEN BLOWER.

**PARTS KITS ARE AVAILABLE AS FOLLOWS:
57/81 – P/N 29241**

Parts List for Model 9000 64/67 Series Blowers

ITEM NO.	PART DESCRIPTION	64 QTY	67 QTY
1	Mechanical Seal Rotor	2	2
3	Housing	1	1
4	End Plate	2	2
6	Drive End Cover	1	1
7	Free End Cover	1	1
8	Timing Gear Set	1	1
9	Bearing, Drive End	2	2
10	Bearing, Free End	2	2
14	Retainer	2	2
15	Retainer	2	2
16	Timing Gear Shim	2	2
20	Slinger	1	1
22	Dowel Pin	6	6
23	Drive Shaft Key	1	1
24	Gear Key	2	2
25	Rotor Shaft Washer	2	2
26	Cap Screw	88	88
29	Cap Screw	8	8
31	Magnetic Plug	2	2
38	Port	2	2
42	Nameplate	1	1
45	Drive Shaft	1	1
47	Retaining Ring	1	1
50	Roller Bearing	1	1
51	Seal	4	4
54	Mechanical Seal	4	4
55	Spacer	2	2
62	Cap Screw	20	20
66	Cap Screw	4	4
69	Cap Screw	4	4
70	Oil Sight Gauge	1	1
76	Seal Rotor	1	1
76	Seal Stator	1	1
78	Retaining Ring	1	1

ITEM NO.	PART DESCRIPTION	64 QTY	67 QTY
91	Seal Adapter	1	1
92	O-Ring	1	1
93	Cap Screw	4	4
109	Pipe Plug	1	1
121	Pipe Plug	4	4
140	O-Ring	1	1
174	Pipe Plug	15	15
176	O-Ring	2	2
195	Lifting Lug	2	2
196	Cap Screw	4	4
197	Spacer	1	1
199	O-Ring	2	2
219	Retaining Ring	4	4
220	Retaining Ring	2	2
224	Oil Retainer	1	1
225	Cap Screw	4	4
226	Lock Washer	4	4
232	Pipe Plug	4	4
233	O-Ring	8	8
255	Roll Pin	1	1
278	Coolant Block	1	1
279	O-Ring	1	1
300	Roll Pin	4	4
304	Mounting Foot	4	4
307	Cap Screw	8	8
314	O-Ring	1	1
339	Straight Thread Plug	1	1

NOTES:

- QUANTITIES SHOWN ARE MAXIMUM VALUES. QUANTITIES MAY VARY BETWEEN BLOWER.

**PARTS KITS ARE AVAILABLE AS FOLLOWS:
64/67 – P/N 29220.**

Parts List for Model 9000 66/69 Series Blowers

ITEM NO.	PART DESCRIPTION	66 QTY	69 QTY
1	Mechanical Seal Rotor	2	2
3	Housing	1	1
4	End Plate	2	2
6	Drive End Cover	1	1
7	Free End Cover	1	1
8	Timing Gear Set	1	1
9	Bearing, Drive End	2	2
10	Bearing, Free End	2	2
14	Retainer	2	2
15	Retainer	2	2
16	Timing Gear Shim	2	2
20	Slinger	1	1
22	Dowel Pin	8	8
23	Drive Shaft Key	1	1
24	Gear Key	2	2
25	Rotor Shaft Washer	2	2
26	Cap Screw	96	96
29	Cap Screw	8	8
31	Magnetic Plug	2	2
38	Port	2	2
42	Nameplate	1	1
45	Drive Shaft	1	1
47	Retaining Ring	1	1
50	Roller Bearing	1	1
51	Seal	4	4
52	Oil Filter Spacer	1	1
54	Mechanical Seal	4	4
55	Spacer	2	2
62	Cap Screw	20	20
66	Cap Screw	4	4
69	Cap Screw	4	4
70	Oil Sight Gauge	1	1
76	Seal Rotor	1	1
76	Seal Stator	1	1
78	Retaining Ring	1	1
91	Seal Adapter	1	1
92	O-Ring	1	1
93	Cap Screw	4	4
102	Pipe, 1/4 NPT	5	5
105	Pipe, 1/2 - STL	1	1
109	Pipe Plug	2	2
117	Lock Washer	3	3
121	Pipe Plug	4	4
124	Spin-On Oil Filter	1	1
136	Lock Washer	6	6
140	O-Ring	1	1
144	Oil Pump	1	1
147	Tube	1	1
148	Tube Connector	6	6
149	Pipe	1	1
150	Tube	1	1
155	Tube Elbow	1	1
161	Tube	2	2
162	Tube	1	1
163	Tube Elbow	6	6
165	Tube Connector	1	1
167	Pipe	1	1
168	Reducer Bushing	1	1
172	Reducer Bushing	1	1

ITEM NO.	PART DESCRIPTION	66 QTY	69 QTY
173	Heat Exchanger	1	1
174	Pipe Plug	11	11
176	O-Ring	2	2
179	Tube, Al	1	1
190	Tube, Al	1	1
195	Lifting Lug	2	2
196	Cap Screw	4	4
199	O-Ring	2	2
219	Retaining Ring	4	4
220	Retaining Ring	2	2
224	Oil Retainer	1	1
225	Cap Screw	4	4
226	Lock Washer	4	4
228	Cap Screw	3	3
232	Pipe Plug	4	4
233	O-Ring	8	8
252	Cap Screw	4	4
253	Cap Screw	6	6
254	Cap Screw	2	2
255	Roll Pin	1	1
256	Tube Elbow	2	2
257	Cross NPT	1	1
259	Reducing Tee	4	4
261	Reducing Elbow	1	1
262	Gauge, Liquid-Filled	1	1
265	Bypass Relief Valve	1	1
267	Oil Pump Shaft	1	1
270	Adapter	1	1
275	Oil Pump Coupling	1	1
278	Coolant Block	1	1
279	O-Ring	1	1
285	Pipe	1	1
290	Reducer Bushing	1	1
300	Roll Pin	4	4
304	Mounting Foot	4	4
307	Cap Screw	8	8
312	Tee	1	1
313	Adapter	1	1
314	O-Ring	1	1
325	O-Ring	1	1
336	Orifice Fitting	5	5
339	Straight Thread Plug	1	1
349	Pipe	1	1
351	Pipe	4	4
354	Reducer Bushing	5	5
360	Oil Filter Threaded Tube	1	1
361	O-Ring	1	1
368	Tee	1	1
369	Tube, Al	2	2
398	Reducer Coupling	1	1

NOTES:

- QUANTITIES SHOWN ARE MAXIMUM VALUES. QUANTITIES MAY VARY BETWEEN BLOWER.

**PARTS KITS ARE AVAILABLE AS FOLLOWS:
64/67 – P/N 29220.**

ASSEMBLY DRAWINGS

Model 9000 17/46 – Cutaway View

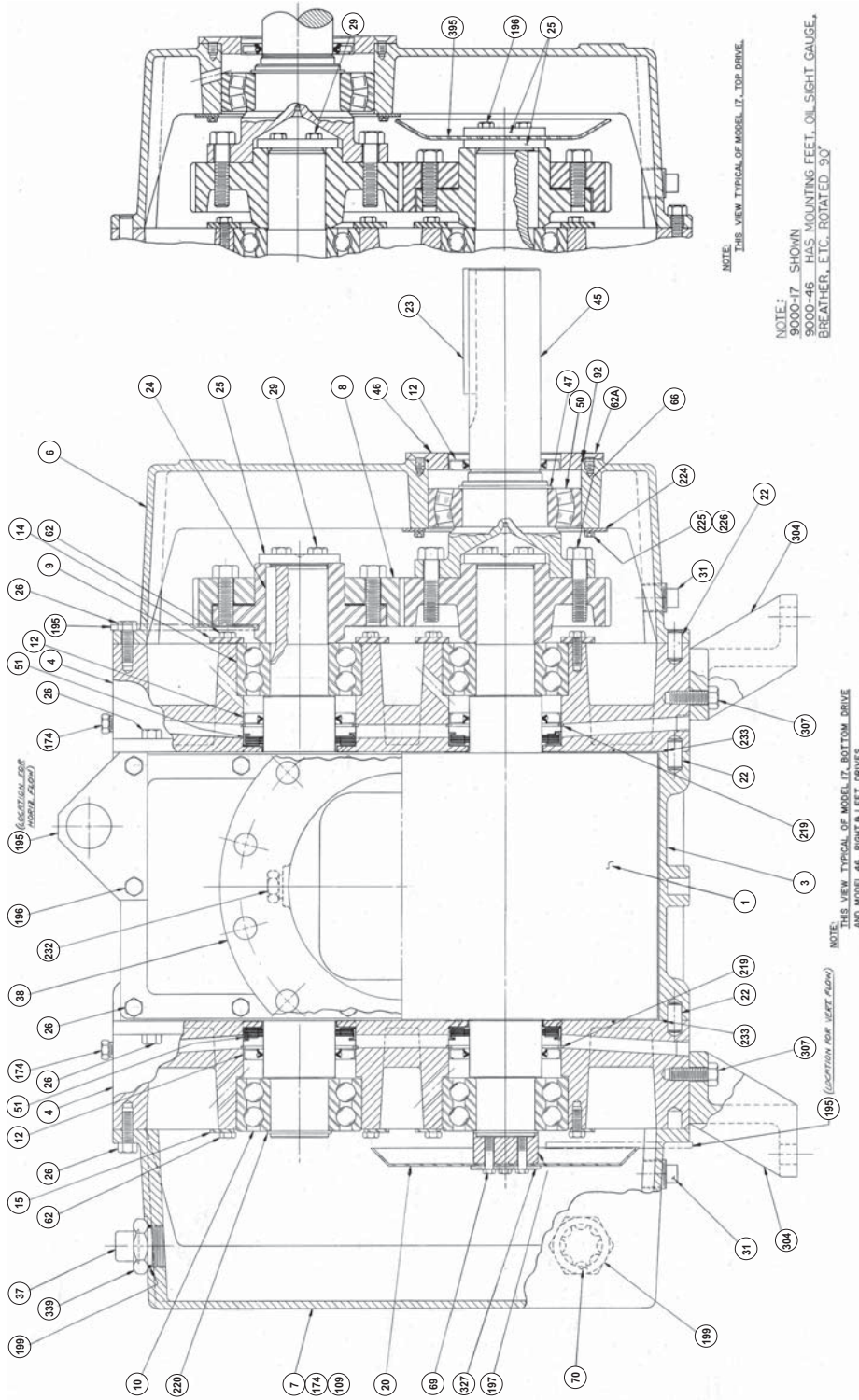

Model 9000 19/86 – Cutaway View

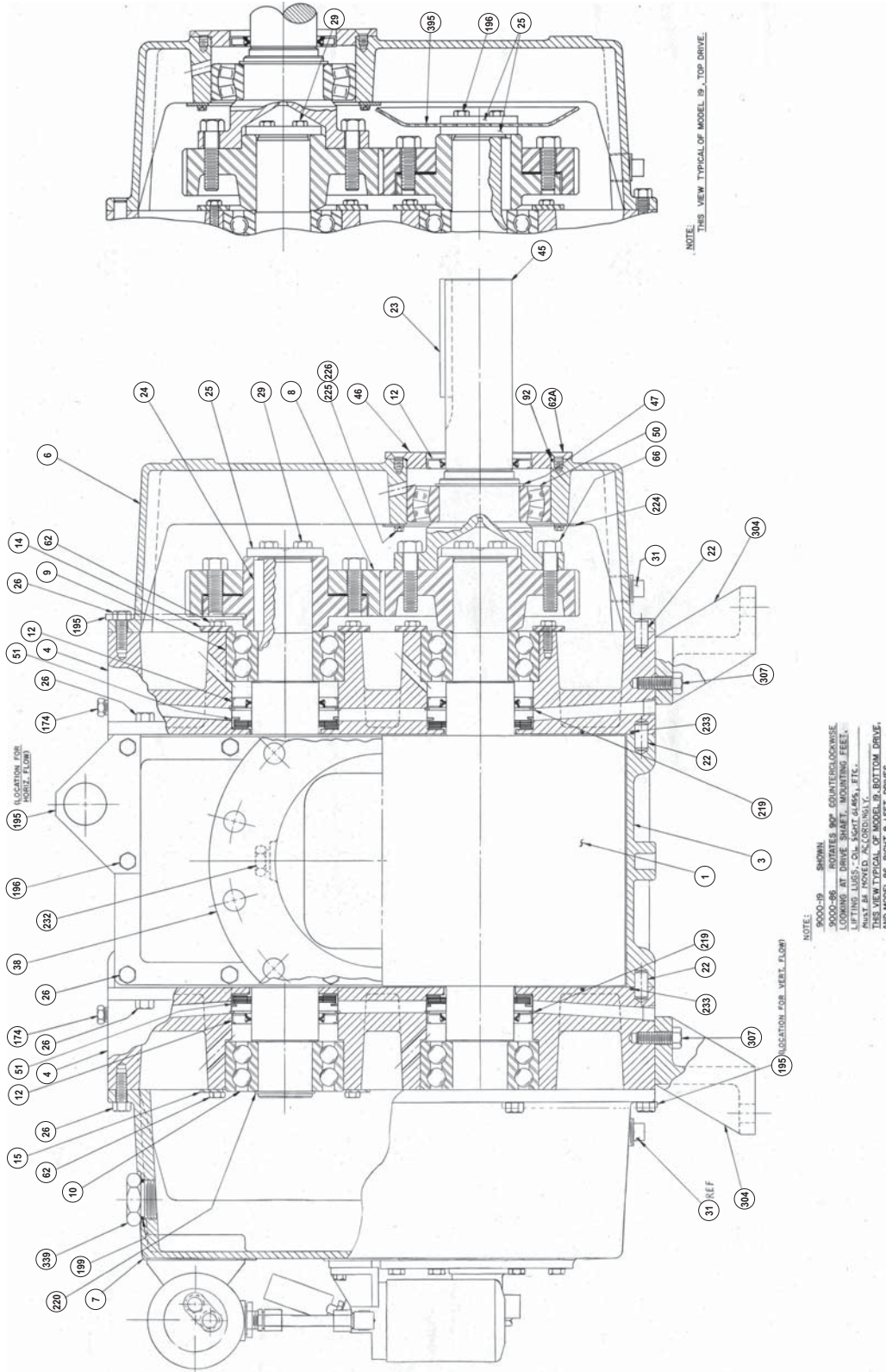

Model 9000 19/86 – Cutaway View

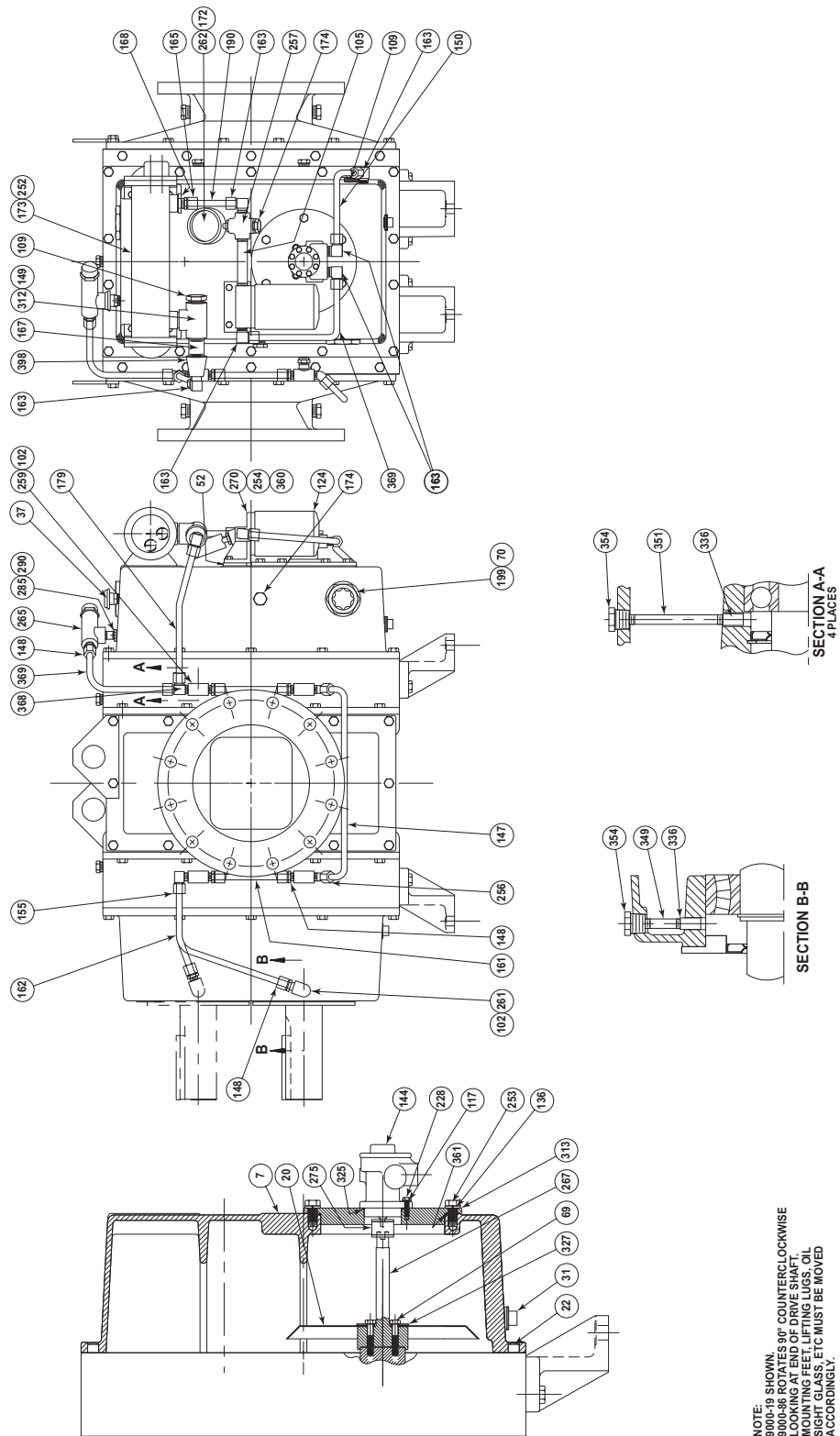

NOTE:
 9000-19 SHOWN.
 9000-86 ROTATES 90° COUNTERCLOCKWISE
 LOOKING AT END OF DRIVE SHAFT.
 MOUNTING FEET, LIFTING LUGS, OIL
 LUGS, ETC. MUST BE MOVED
 ACCORDINGLY.

Model 9000 55/82 – Cutaway View

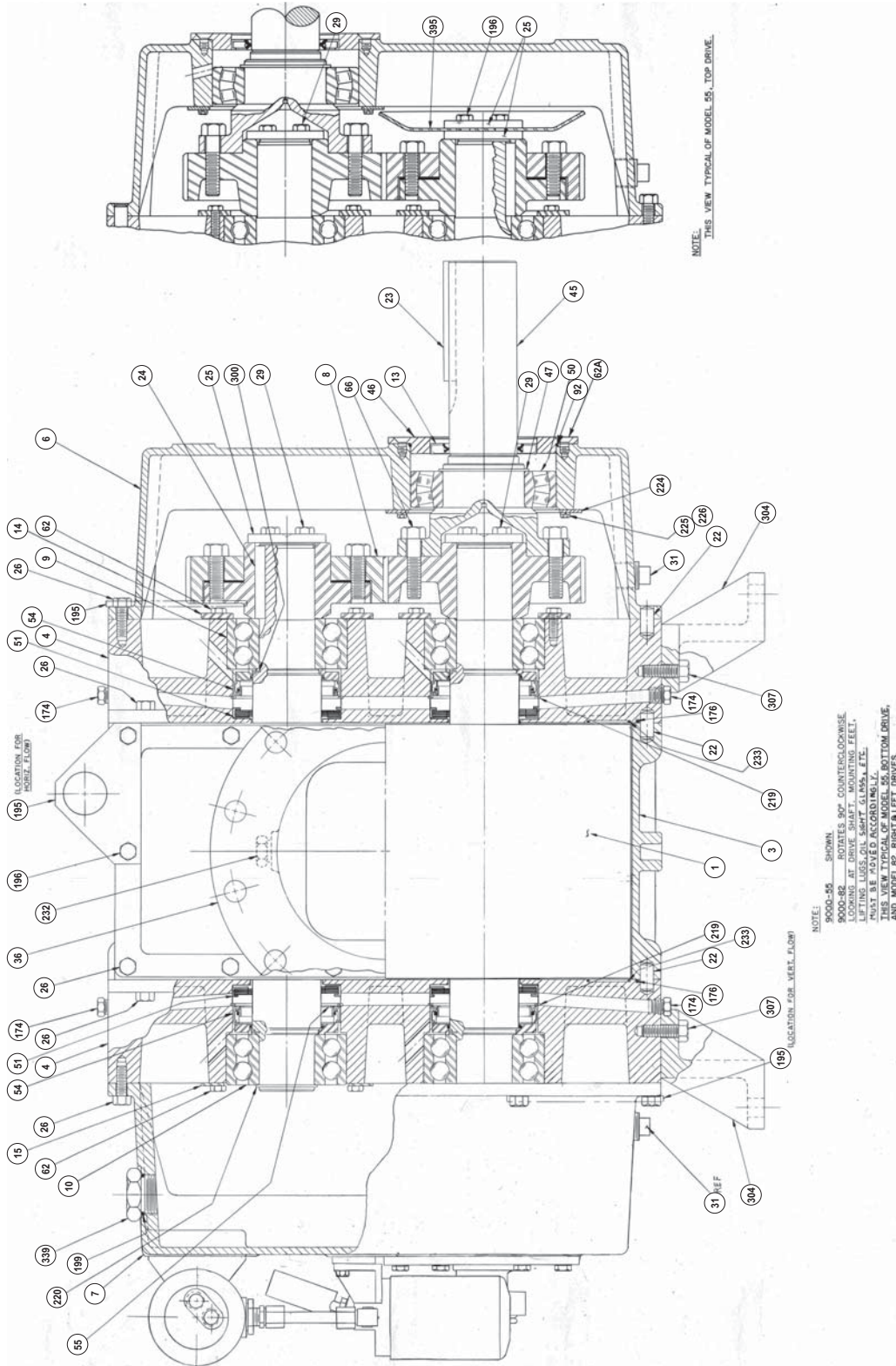

Model 9000 57/81 – Cutaway View

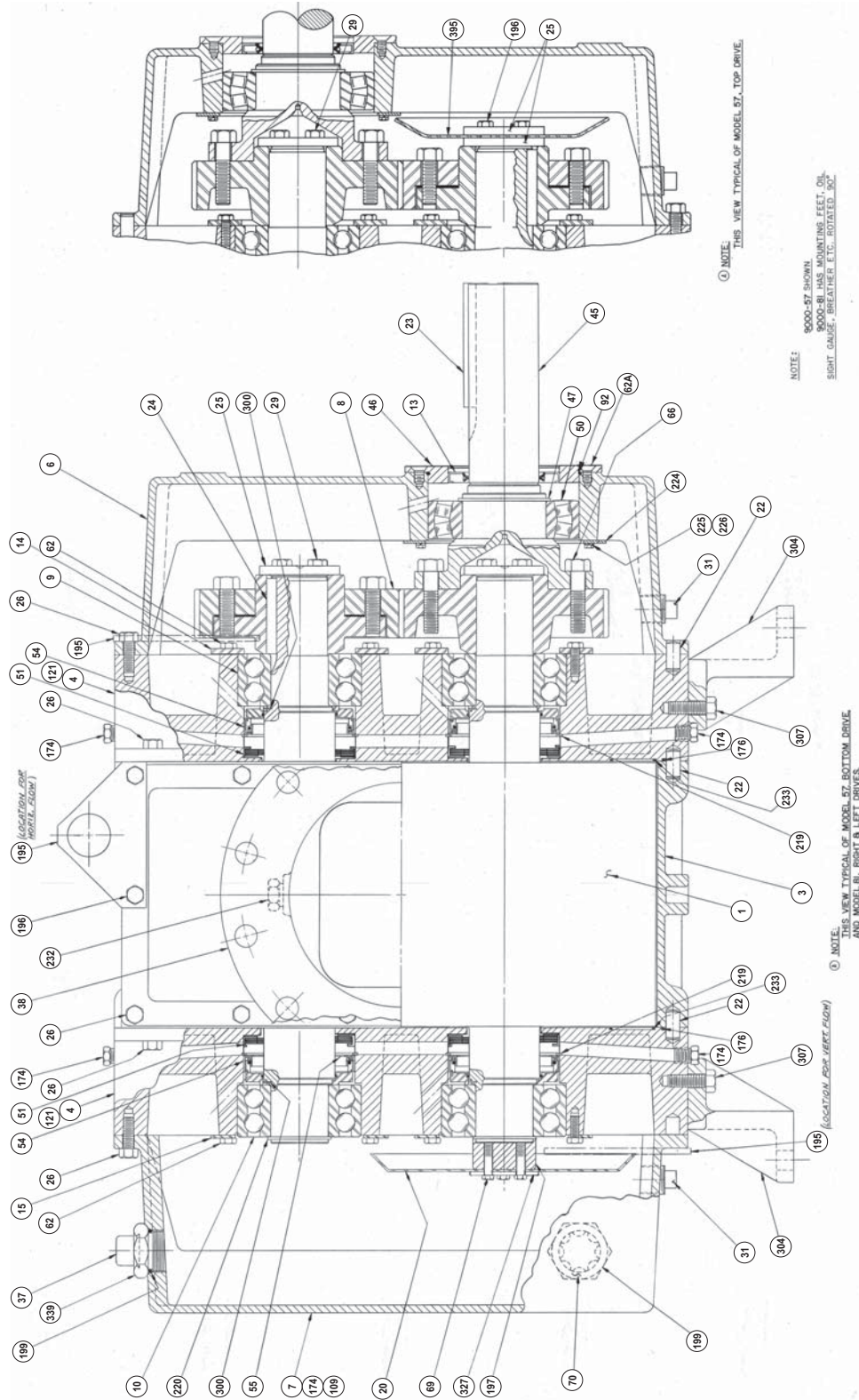

Model 9000 64/67 – Cutaway View

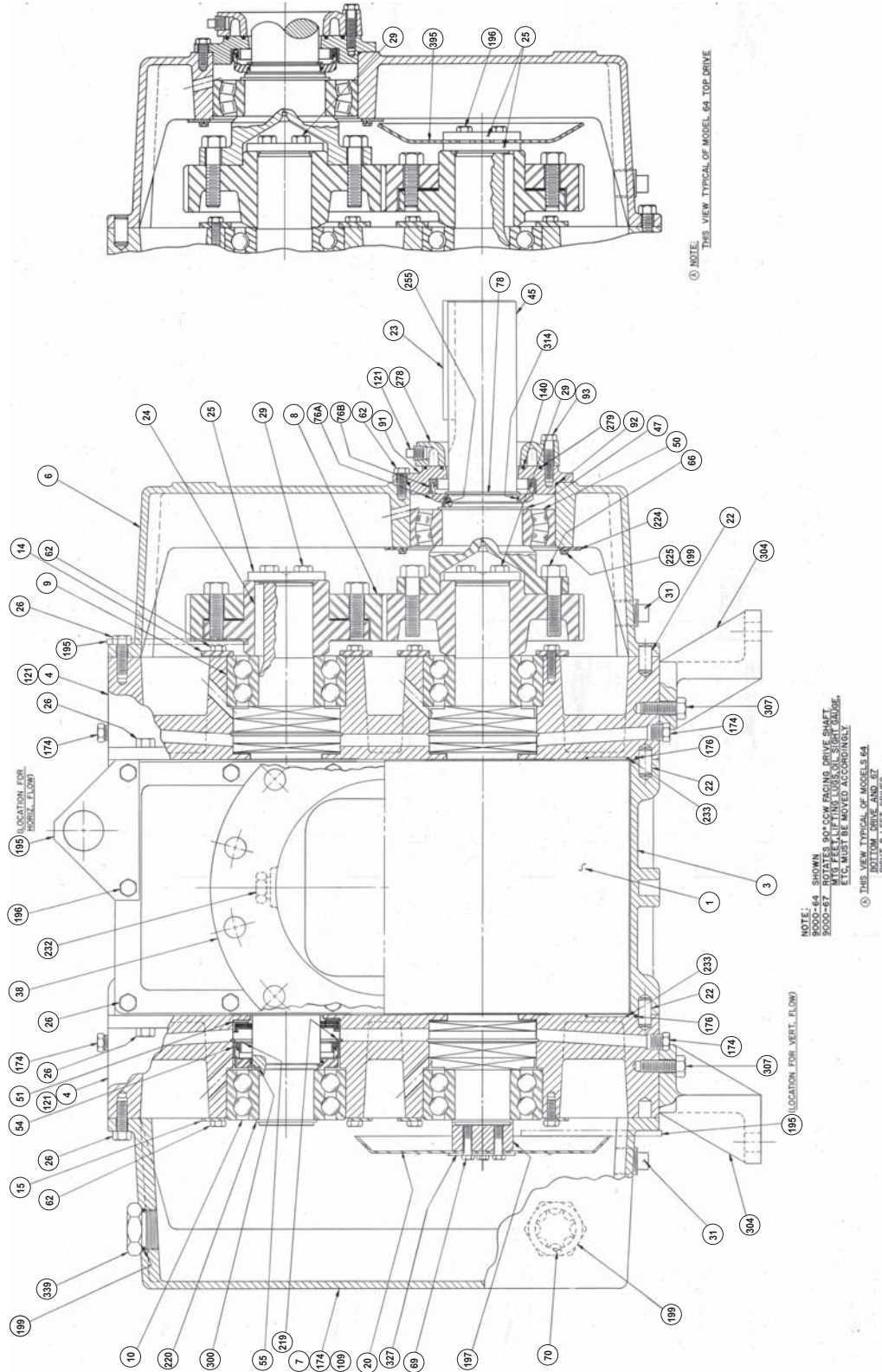

Model 9000 66/69 – Cutaway View

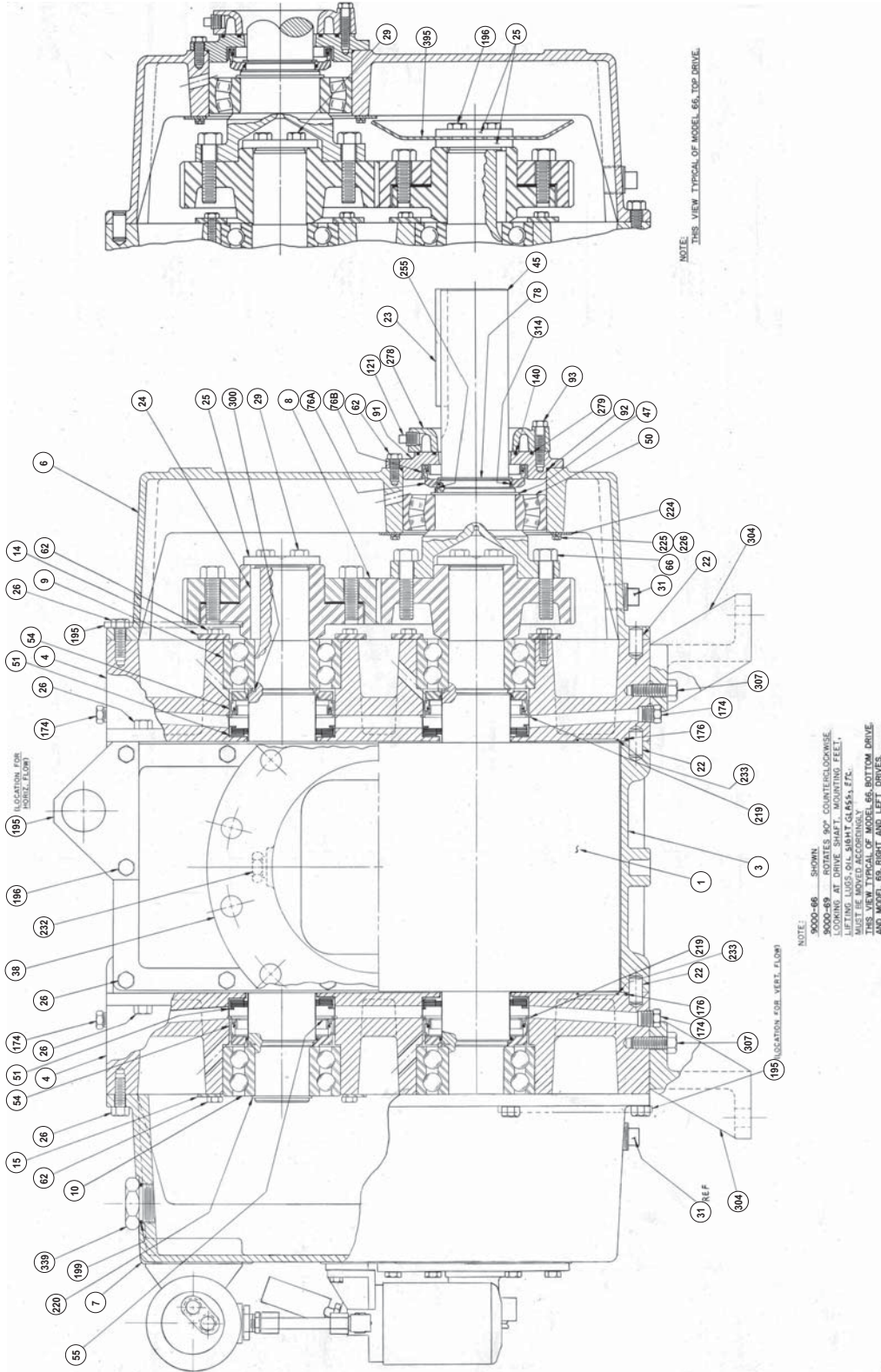

Model 9000 66/69 – Cutaway View

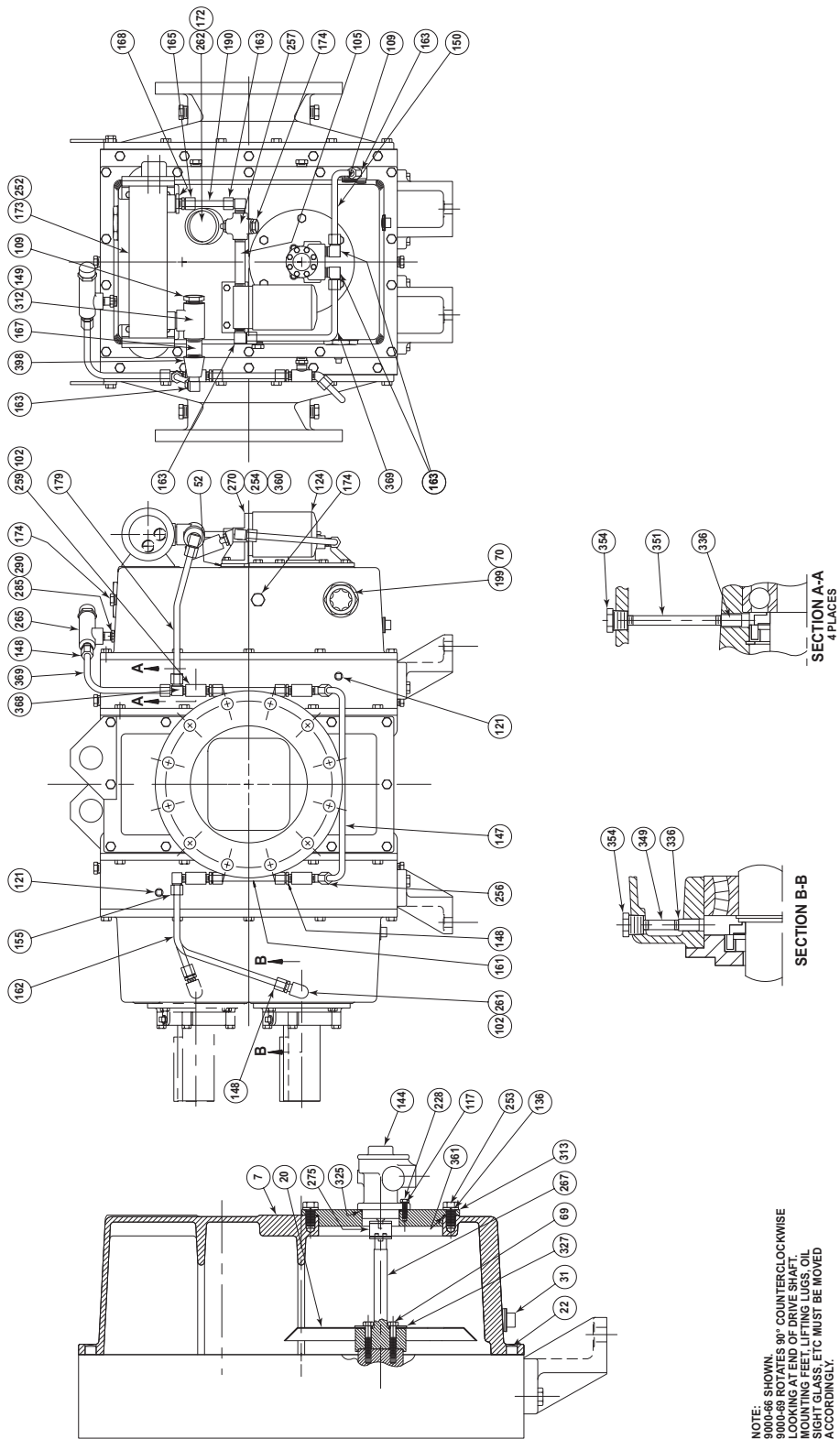

NOTE:
 9000-66 SHOWN.
 9000-69 ROTATES 90° COUNTERCLOCKWISE
 LOOKING AT END OF DRIVE SHAFT.
 LIFTING PLUGS, LIFTING BEARS, LIFTING
 SIGNALS, ETC MUST BE MOVED
 ACCORDINGLY.



4840 W. KEARNEY ST., SPRINGFIELD, MO 65803 • P (417) 865-8715 • F (417) 865-2950



DECLARATION OF INCORPORATION

Herewith we declare that the items detailed below are in conformity with the provisions of the Machinery Directive 2006/42/EC.

Information on the items detailed are compiled per the Machinery Directive 2006/42/EC, Annex VII, part A and are the responsibility of the person listed below.

The items detailed below must not be put into service until the machinery into which it is to be incorporated has been declared in conformity with the provisions of the relevant directive(s).

Other directives and standards that apply to this Declaration of Incorporation:

EN 1012-1:1996 - Compressors and vacuum pumps - Safety requirements - Part 1: Compressors

The scope of the Declaration of Incorporation is for bare shaft Rotary Positive Displacement (PD Plus) Blowers

Models
3200, 4000, 5500, 7000, 9000, 1200

David Schardt
Vice President of Engineering
Tuthill Vacuum & Blower Systems

WHEN WE COME ALIVE



THE WORLD COMES ALONG

WARRANTY – BLOWER PRODUCTS

Subject to the terms and conditions hereinafter set forth and set forth in General Terms of Sale, Tuthill Vacuum & Blower Systems (the Seller) warrants products and parts of its manufacture, when shipped, and its work (including installation and start-up) when performed, will be of good quality and will be free from defects in material and workmanship. This warranty applies only to Seller's equipment, under use and service in accordance with seller's written instructions, recommendations and ratings for installation, operating, maintenance and service of products, for a period as stated in the table below. Because of varying conditions of installation and operation, all guarantees of performance are subject to plus or minus 5% variation. (Non-standard materials are subject to a plus or minus 10% variation)

PRODUCT TYPE	TYPE OF APPLICATION	
	ATMOSPHERIC AIR OR PROCESS AIR WITHOUT LIQUIDS PRESENT	PROCESS GASES OTHER THAN AIR, OR ANY LIQUID INJECTED APPLICATION
New <i>(Qx™ models only)</i>	30 months from date of shipment, or 24 months after initial startup date, whichever occurs first.	Consult Factory
New <i>(all other models)</i>	24 months from date of shipment, or 18 months after initial startup date, whichever occurs first	18 months from date of shipment, or 12 months after initial startup date, whichever occurs first
Repair	12 months from date of shipment, or remaining warranty period, whichever is greater	12 months from date of shipment, or remaining warranty period, whichever is greater

THIS WARRANTY EXTENDS ONLY TO BUYER AND/OR ORIGINAL END USER, AND IN NO EVENT SHALL THE SELLER BE LIABLE FOR PROPERTY DAMAGE SUSTAINED BY A PERSON DESIGNATED BY THE LAW OF ANY JURISDICTION AS A THIRD PARTY BENEFICIARY OF THIS WARRANTY OR ANY OTHER WARRANTY HELD TO SURVIVE SELLER'S DISCLAIMER.

All accessories furnished by Seller but manufactured by others bear only that manufacturer's standard warranty.

All claims for defective products, parts, or work under this warranty must be made in writing immediately upon discovery and, in any event within one (1) year from date of shipment of the applicable item and all claims for defective work must be made in writing immediately upon discovery and in any event within one (1) year from date of completion thereof by Seller. Unless done with prior written consent of Seller, any repairs, alterations or disassembly of Seller's equipment shall void warranty. Installation and transportation costs are not included and defective items must be held for Seller's inspection and returned to Seller's Ex-works point upon request.

THERE ARE NO WARRANTIES, EXPRESSED, IMPLIED OR STATUTORY WHICH EXTEND BEYOND THE DESCRIPTION ON THE FACE HEREOF, INCLUDING WITHOUT LIMITATION, THE IMPLIED WARRANTIES OF MERCHANTABILITY AND FITNESS OF PURPOSE.

After Buyer's submission of a claim as provided above and its approval, Seller shall at its option either repair or replace its product, part, or work at the original Ex-works point of shipment, or refund an equitable portion of the purchase price.

The products and parts sold hereunder are not warranted for operation with erosive or corrosive material or those which may lead to build up of material within the product supplied, nor those which are incompatible with the materials of construction. The Buyer shall have no claim whatsoever and no product or part shall be deemed to be defective by reason of failure to resist erosive or corrosive action nor for problems resulting from build-up of material within the unit nor for problems due to incompatibility with the materials of construction.

Any improper use, operation beyond capacity, substitution of parts not approved by Seller, or any alteration or repair by others in such manner as in Seller's judgment affects the product materially and adversely shall void this warranty.

No employee or representative of Seller other than an Officer of the Company is authorized to change this warranty in any way or grant any other warranty. Any such change by an Officer of the Company must be in writing.

The foregoing is Seller's only obligation and Buyer's only remedy for breach of warranty, and except for gross negligence, willful misconduct and remedies permitted under the General Terms of Sale in the sections on CONTRACT PERFORMANCE, INSPECTION AND ACCEPTANCE and the PATENTS Clause hereof, the foregoing is BUYER'S ONLY REMEDY HEREUNDER BY WAY OF BREACH OF CONTRACT, TORT OR OTHERWISE, WITHOUT REGARD TO WHETHER ANY DEFECT WAS DISCOVERED OR LATENT AT THE TIME OF DELIVERY OF THE PRODUCT OR WORK. In no event shall Buyer be entitled to incidental or consequential damages. Any action for breach of this agreement must commence within one (1) year after the cause of action has occurred.

OPERATING DATA FORM / PRODUCT REGISTRATION

It is to the user's advantage to have the requested data filled in below and available in the event a problem should develop in the blower or the system. This information is also helpful when ordering spare parts.

Model No.		V-Belt Size		Length	
Serial No.		Type of Lubrication			
Start-up Date					
Pump RPM		Operating Vacuum			
Pump Sheave Diameter		Any Other Special Accessories Supplied or in Use:			
Motor Sheave Diameter					
Motor RPM		HP			

NOTES:

IMPORTANT

All blowers manufactured by Tuthill Vacuum & Blower Systems are date-coded at time of shipment. In order to assure you of the full benefits of the product warranty, please complete, tear out and return the product registration card, or register online at tuthillvacuumblower.com.



Technical Support: 1-877-955-TECH (8324)

Service & Repair or Product Sales:

Tuthill Vacuum & Blower Systems
4840 West Kearney Street
Springfield, Missouri USA 65803-8702
O 417.865.8715 800.825.6937
F 417.865.2950
tuthillvacuumblower.com



Manual 2008 Rev B p/n 2008

1/18